

# Model SLS 9400 Colorimeter

**MANUAL P/N 79-10-052**

**REVISION: G**

**DATE: Nov 05, 2010**

**SOFTWARE REV: S9.19**

**DATE: Nov 05, 2010**

**UDT Instruments  
8581 Aero Drive  
San Diego, CA 92123  
USA**

**TEL: 858 279-8034**

**FAX: 858 576-9286**

***UDT* INSTRUMENTS**

*A Gamma Scientific company*

---

**TABLE OF CONTENTS**

---

	Page:
<b>General Information</b>	1
<b>Introduction</b>	1
<b>Model SLS 9400 Features</b>	2
<b>Calibration</b>	4
<b>Caution</b>	4
<b>Electrostatic-Sensitive Device</b>	4
<b>Preparation for use</b>	5
<b>Model SLS 9400 Inspection</b>	5
<b>Storage and Shipping</b>	5
<b>Instrument Identification</b>	5
<b>Input Power Requirements</b>	5
<b>Turn-on and Check Out Procedure</b>	6
<b>Warm Up Period</b>	6
<b>Ambient Light Blocking Cup</b>	6
<b>Model SLS 9400 Operation</b>	7
<b>Introduction</b>	7
<b>Numeric Display Mode</b>	7
<b>CIE Plot Display Mode</b>	8
<b>RGB Bar Graph Display Mode</b>	9
<b>Instrument Operation</b>	11
<b>Icons</b>	11
<i>Stop</i>	11
<i>Display Mode</i>	11
<i>Save</i>	11
<i>View</i>	11
<i>Configuration</i>	11
<b>Menu Options</b>	12
<b>Save Menu</b>	12
<i>Setup</i>	13
<i>Current Measurement</i>	14
<i>White Reference</i>	15
<i>Color Standard</i>	16
- <i>Manual Entry Mode</i>	17
- <i>Learn Mode</i>	17
<i>RS232</i>	18
<b>View Menu</b>	18
<b>Instrument Configuration (screen 1)</b>	18
<i>Recall Stored Setup Parameters</i>	19
<i>View Current Setup Parameters</i>	19
<i>Set Measurement Mode</i>	20
<i>Luminance Units</i>	21

---

<i>Bar Graph Mode</i>	21
<i>White Reference</i>	21
<i>Color Standard</i>	22
<i>RGB Reference</i>	22
<i>Delta Reference</i>	22
<i>Power Saver</i>	22
<i>Next Screen</i>	22
<b>Instrument Configuration (screen 2)</b>	23
<i>Recall Reference</i>	23
<i>Calibration Type</i>	24
<i>Averaging</i>	24
<i>Calibration Info</i>	24
<i>Time and date settings</i>	25
<i>Emulation mode</i>	25
<b>RS-232 Serial Communication Parameters and Commands</b>	26
<b>Introduction</b>	26
<b>Connection Diagram</b>	26
<b>RS-232 Connector Configuration</b>	26
<b>RJ14 Standard wiring of Data Link Cable</b>	27
<b>Pin Assignments on RJ Connector</b>	27
<b>Communication Protocol</b>	28
<b>Support of virtual Serial Ports created by USB-To-RS232 Converters</b>	28
<b>Command Nomenclature</b>	29
<b>Return Values</b>	29
<b>Commands</b>	29
<i>Anx:</i>	30
<i>BMx:</i>	30
<i>BR0:</i>	30
<i>BR1,#:</i>	30
<i>CS:</i>	31
<i>C-:</i>	31
<i>C+:</i>	31
<i>C#:</i>	32
<i>DDx:</i>	32
<i>DMx:</i>	33
<i>DRy,#:</i>	33
<i>E?#:</i>	33
<i>EC#:</i>	34
<i>ES#,&lt;name&gt;:</i>	34
<i>EI#:</i>	34
<i>F?#:</i>	34
<i>FC#:</i>	36
<i>FS#,&lt;name&gt;:</i>	36
<i>G:</i>	36
<i>H:</i>	37

---

<i>Kx:</i>	37
<i>Lx:</i>	37
<i>Mx:</i>	37
<i>N?#,y:</i>	38
<i>NC#:</i>	38
<i>NI#:</i>	38
<i>ND#,y,D:</i>	39
<i>O:</i>	39
<i>Px:</i>	39
<i>Q:</i>	40
<i>R:</i>	41
<i>S:</i>	42
<i>Ux:</i>	42
<i>W?#,y:</i>	42
<i>WC#:</i>	43
<i>WI#:</i>	43
<i>WD#,y,D:</i>	43
<i>WS#,&lt;name&gt;</i>	44
<b>Return Status Information:</b>	44
<i>Overall Error</i>	46
<i>Cal Expired</i>	46
<i>Invalid Command</i>	46
<i>Backlight</i>	46
<i>Overrange</i>	46
<i>Underrange</i>	46
<i>Power Saver</i>	47
<i>Bar Graph Mode</i>	47
<i>Reference Option</i>	47
<i>Reference Reading</i>	47
<i>Display Disable</i>	47
<i>Hold</i>	47
<i>Display Mode</i>	47
<i>Keypad Lockout</i>	48
<i>Chroma Mode</i>	48
<i>Luminance Units</i>	48
<i>Handheld Not Calibrated</i>	48
<i>Head not Calibrated</i>	48
<i>Color Standard Vacant</i>	49
<i>White Reference Vacant</i>	49
<i>Measurement Vacant</i>	49
<i>Setup Vacant</i>	49
<i>White Reference</i>	49
<i>Color Standard</i>	49
<b>Maintenance</b>	50
<b>Appendix A</b>	51

<b>Model SLS 9400 RS-232 Commands and Command Execution Times</b>	51
<b>Appendix B</b>	54
<b>Model SLS 9400 Sample C Functions &amp; Status</b>	54
<b>Appendix C</b>	59
<b>Product Specifications</b>	59
<b>Appendix D</b>	63
<b>Reference Information</b>	63
<b>Color Standards</b>	63
<b>Standard Illuminants</b>	63
<b>Appendix E</b>	64
<b>Product Warranty</b>	64
<b>Appendix F</b>	66
<b>Return Report</b>	66

## **General Information**

### **Introduction**

With the ever increasing requirements to the quality of displayed images in medical diagnostics, broadcasting, video production, animation, education, computer graphics, and advertising, a way to insure accurate color presentation from the display units has become critical. The Model SLS 9400 Colorimeter has been specifically designed to meet the demand for a low cost, easy to use, high precision instrument to control and allow easy adjustment of the color and brightness on any monitor.

The UDT Instruments Model SLS 9400 Colorimeter is the upgraded version of well known UDT Instruments SLS 9400 colorimeter with new capability to measure Flat Panel Displays (FPD) and expanded functionality.

The Model SLS 9400 has direct application in:

- Video and post production
- TV studios
- Medical Imaging
- Advertising
- Computer Graphics
- Desktop publishing
- Display manufacturing
- Animation
- Video wall presentations, and

any other application where the need to control absolute color accuracy is a necessity.

The Model SLS 9400 Colorimeter consists of a sensor head and a handheld display unit. A built-in rechargeable battery pack allows the instrument to be operated anywhere and the RS-232 serial communication port makes remote data collection simple.

The key to high accuracy of the Model SLS 9400 is its ability to match the color response of the human eye, as defined by the CIE 1931 standard observer spectral response functions. This match allows the user to make very accurate color and luminance measurements across the full color gamut of a monitor. The accuracy of a colorimeter depends on how closely the instrument's spectral response matches the CIE 1931 standard observer spectral response. The Model SLS 9400's unique, proprietary sensor/filter design very closely mirrors these spectral response curves resulting in highly accurate chromaticity measurements that are independent of field rate or the monitor's color gamut and yielding precision white balancing capability. Luminance is measured using a detector/filter combination, which closely matches the response of the human eye as defined by the CIE Luminous Efficiency Function. This gives the Model SLS 9400 the ability to accurately measure the luminance of a monitor.

Unlike instruments that use three detectors, or unstable (temperature and time sensitive) interference, plastic or gelatin filters, the Model SLS 9400 uses four precision silicon photodiodes with highly stable colored glass filters. By using four detector/filter combinations, the Model SLS 9400 can accurately match the complete set of tristimulus functions.

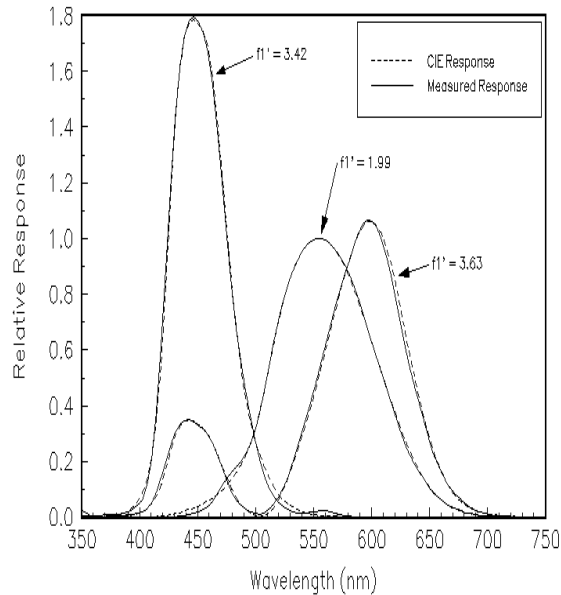

The Model SLS 9400's ergonomic design allows the instrument to rest firmly on a table top, or to be operated with one hand, leaving the other hand free to make any required monitor adjustments. It has a backlit 128 x 128 dot matrix LCD display to make measurements in dim lighting conditions.

Measurements can be displayed in three modes. An analog bar graph displaying RGB values used to perform color balance adjustments or two numeric mode options for the display of absolute color coordinates. Simple, precise, portable, and affordable, the Model SLS 9400 puts laboratory quality measurements in the palm of your hand.

### Model SLS 9400 Features

- Remote computer control using RS-232 interface (which can be disabled)
- Large backlit 128 x 128 graphics LCD display with an anti-glare coating
- Numeric modes
  - CIE 1931  $xyY$
  - CIE 1976  $u'v'Y$
  - CIE 1931  $\Delta x \Delta y Y$

- CIE 1976  $\Delta u' \Delta v' Y$
  - CIE 1931 XYZ
- CIE plot modes
  - CIE 1931 xyY
  - CIE 1976 u'v'Y
  - CIE 1931  $\Delta x \Delta y Y$
  - CIE 1976  $\Delta u' \Delta v' Y$
- RGB bar graph mode
- Five storage location for Color and Luminance calculation matrixes (calibrations)
- Nine reference measurement storage locations
- Six memory storage locations for color standards
- Six white reference memory storage locations
- Five memory storage locations for setup information
- Adjustable averaging function
- Display hold
- Battery saver (which can be disabled)
- Calibration reminder
- Field calibration capability
- Universal input power supply (100 to 240 volts AC)
- A standard 1/4"-20 threaded hole for mounting on a post or tripod on both the detector and display unit.

**Calibration**

To insure the high accuracy of color and luminance measurements, the model SLS 9400 Colorimeter is supplied with three standard calibrations which match the most popular types of displays on the market: CRT, FPD with CCFL backlight, and FPD with LED backlight (refer to page 24 for more details how to select proper colorimeter calibration).

Custom calibrations (for a specific display or type of display panel) can be performed upon request.

The calibration of the UDT Instruments Model SLS 9400 is traceable to the National Institute of Standards and Technology (NIST) and Physikalisch-Technische Bundesanstalt (PTB).

The Model SLS 9400 has a built-in calibration reminder. This feature informs the user that the instrument needs to be recalibrated when the calibration cycle elapses. When the instrument needs to be recalibrated, the calibration information will be displayed every time the instrument is turned on.

**Caution**

Use only the battery charger supplied with the instrument. Failure to do so may cause permanent damage to the Model SLS 9400 and may result in personal injury. To avoid electrical shock, use proper care when using the battery charger.

**Electrostatic-Sensitive Device**

All semiconductor devices are susceptible to electrostatic discharges (ESD). Ensure that the unit is switched off before connecting or disconnecting the detector probe, battery charger, and RS-232 cable. Failure to do so can cause ESD damage and reduce the lifetime of the instrument drastically.

## **Preparation for use**

### **Model SLS 9400 Inspection**

The Model SLS 9400 shipping carton contains the following items:

- Model SLS 9400 colorimeter
- Hardside carrying case
- Universal AC input battery charger with AC power cord
- RS-232 adapter with data cord
- Instruction manual on CD
- Certificate of calibration.

The instrument was inspected prior to shipment and was free of mechanical and electrical defects. Immediately after unpacking the instrument, inspect for damage that may have occurred during transit. If any damage is found, a claim should be filed with the carrier and UDT Instruments should be contacted for a Return Materials Authorization (RMA) number.

### **Storage and Shipping**

To prevent damage to the instrument, it is recommended that the package designed for the instrument is used for shipping. The original packaging is intended to be used for shipping, carrying, and storage.

### **Instrument Identification**

The model and serial number of the instrument are located on the label attached to the back of the handheld unit. The serial number of the handheld and the detector head can also be determined by viewing the "CALIBRATION INFO" screen via the CONFIGURATION 2 menu.

### **Input Power Requirements**

The Model SLS 9400 receives its primary power from internal batteries. The approximate lifetime of the batteries is fourteen hours without the backlight and seven hours with the backlight.

Before charging the batteries, turn the instrument OFF, plug the battery charger into the instrument, connect the power cord to battery charger and then to the wall socket. With the instrument turned off, the batteries will fully charge in approximately four hours. Because of this fast charging rate, the keypad and the surrounding area will be warm. This is normal and there is no cause for alarm. The operation of the instrument is not affected while the batteries are charging.

**NOTE:** Due to the nature of NiCd batteries, the batteries may exhibit a reduced charge capacity over time. This is typically caused by repetitive partial discharge/recharge cycles. To maintain maximum battery charge capacity, operate the instrument until the battery is fully discharged before recharging.

The battery charger is configured to supply the proper power to the Model SLS 9400 independent of the input voltage and frequency. The charger will function with an input voltage ranging from 100 to 240 volts AC at 47 to 63 Hz. The power supply has UL, CSA and TUV certifications.

### **Turn-on and Check-out Procedure**

Connect the detector probe to the handheld unit, **make sure not to over-tighten the connector**, and press the PWR button. When the power button is depressed the instrument will beep and the icons will be displayed at the bottom of the screen along with a message stating that the instrument is performing a self-calibration. When the self calibration is completed the Model SLS 9400 will start taking measurements based on the configuration information in the DEFAULT setup memory location (see page 13 for more information).

The Model SLS 9400 is fully charged before it leaves the factory. However, if the instrument acts erratically, fully charge the batteries before proceeding with the check out procedure.

### **Warm Up Period**

The Model SLS 9400 can be used immediately after it is turned ON. However, the Model SLS 9400 will perform best if allowed to stabilize for at least 30 minutes before making precision measurements. This is especially critical when making low luminance level color measurements.

### **Ambient Light Blocking Cup**

The Model SLS 9400 is equipped with an ambient light blocking cup, which is mounted at the front of the Optical Detector Head. For maximum performance, the Optical Detector Head has to be in contact with the display surface, while performing measurements in the environment with ambient illumination present. However, Flat Panel Displays (specifically those without a hard cover glass) are susceptible to pressure which alters the panels light emission characteristics. Be advised to avoid excessive pressure onto display surface while performing contact color measurements of the display.

Refer to the specification of the instrument regarding the measurement distance guidelines (see Appendix C) .

Also, the Light Blocking Cup is a convenient tool to align the Optical Detector Head to any display.

## Model SLS 9400 Operation

### Introduction

The Model SLS 9400 operates in three modes: a numeric display mode, a CIE plot mode, and a RGB bar graph mode.

### Numeric Display Mode

The numeric display mode displays the color coordinates of a source, the luminance value in the desired units of measurement, the Correlated Color Temperature and the color error  $\Delta E$ . This mode is used to perform absolute or differential color measurements. The color coordinates can be displayed in the following formats:

- CIE 1931  $xyY$
- CIE 1976  $u'v'Y$
- CIE 1931  $\Delta x\Delta yY$
- CIE 1976  $\Delta u'\Delta v'Y$
- CIE 1931 XYZ

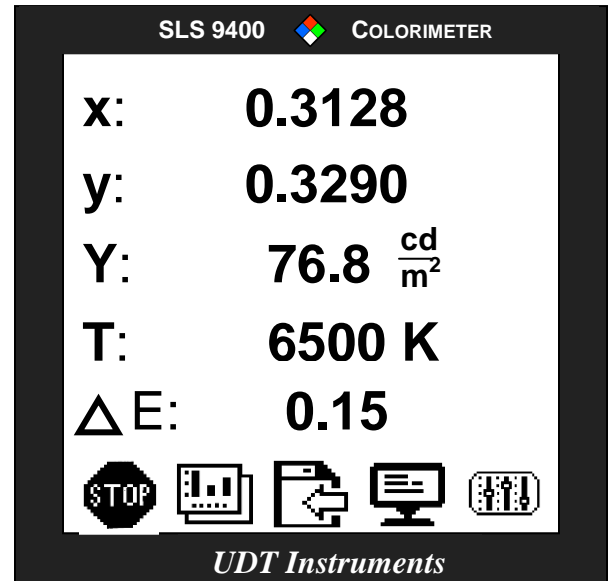

In the CIE 1931  $\Delta x\Delta y$  and CIE 1976  $\Delta u'\Delta v'$  modes, the reference is selected via the DELTA REFERENCE menu option in the CONFIGURATION 1 menu (see page 18). Upon entry into this mode, the displayed delta values are calculated as follows:

In CIE 1931  $\Delta x\Delta y$ :

- $\Delta x = x_{\text{measured}} - x_{\text{ref}}$
- $\Delta y = y_{\text{measured}} - y_{\text{ref}}$

In CIE 1976  $\Delta u'\Delta v'$ :

- $\Delta u' = u'_{\text{measured}} - u'_{\text{ref}}$
- $\Delta v' = v'_{\text{measured}} - v'_{\text{ref}}$

To use a stored measurement value as the reference, it must first be stored in one of the numeric modes to be used in the calculations above.

The Correlated Color Temperature (CCT) is calculated using the method described by A. R. Robertson in *Color Science: Concepts and Methods, Quantitative Data and Formulae*, 2<sup>nd</sup> Edition by Wyszecki and Stiles. Valid CCT range is 2,500 K to 50,000 K.

The  $\Delta E$  (CIELUV) calculation uses as its reference the value selected via the DELTA REFERENCE menu option in the CONFIGURATION 1 menu (see DELTA REFERENCE, page 22). For further explanation of  $\Delta E$  calculations see Wyszecki and Stiles.

### CIE Plot Display Mode

The CIE PLOT MODE displays a graphical representation of the difference between the currently measured color coordinates and the color coordinates of the user specified reference (REF:) where:

- $X = X_{\text{measured}} - X_{\text{ref}}$
- $y = y_{\text{measured}} - y_{\text{ref}}$

and the numeric color coordinates can be displayed in the following formats:

- CIE 1931 xyY
- CIE 1976  $u'v'Y$
- CIE 1931  $\Delta x \Delta y Y$
- CIE 1976  $\Delta u' \Delta v' Y$

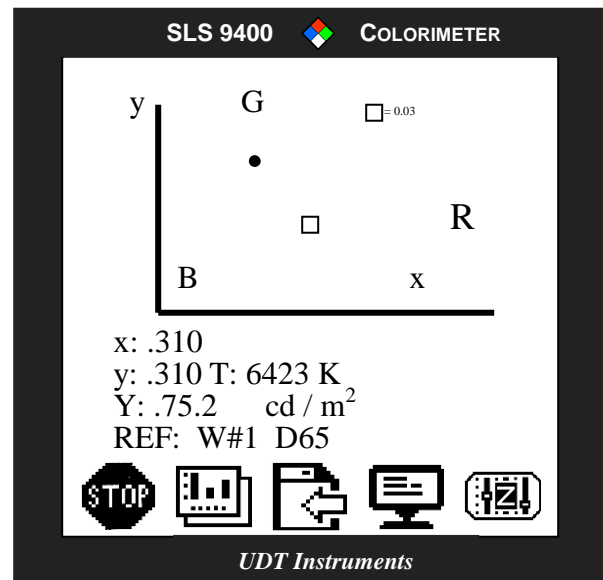

The color reference or target is represented by the  $\square$  in the middle of the graphical area while the " $\square =$ " (shown at the top of the graphical area) indicates the graphical resolution scale. The resolution scales indicate the magnitude of the color difference and can be adjusted manually using the ZOOM-CONFIGURATION icon (see page 11). The available resolution levels are:

- 0.05
- 0.03
- 0.004

During use, the color difference has been minimized within the specified graphically resolution when the  $\blacksquare$  lies within  $\square$ . To illustrate, for maximum resolution the size of the target box needs to be set to " $\square = 0.004$ ". This sets the length of the sides of the target to indicate a color coordinate deviation of 0.004 in either axis. The CIE PLOT MODE is intended as display mode only. RS-232 communications will follow the Numeric Display Mode protocol.

## RGB Bar Graph Display Mode

The RGB bar graph mode shows the color balance between the three primary colors, red, green and blue, in an analog format. When the three values are equal, the color balance corresponds to the selected RGB reference. Balance is achieved when the bars are equal lengths centered in the display. Numerical data is also displayed to present the user with quantitative as well as qualitative data. The RGB reference can either be a stored white reference or a stored measurement. The bar graph mode can display:

- Two of the primary colors related to the third
- Three of the primary colors related to three primary colors of a stored measurement

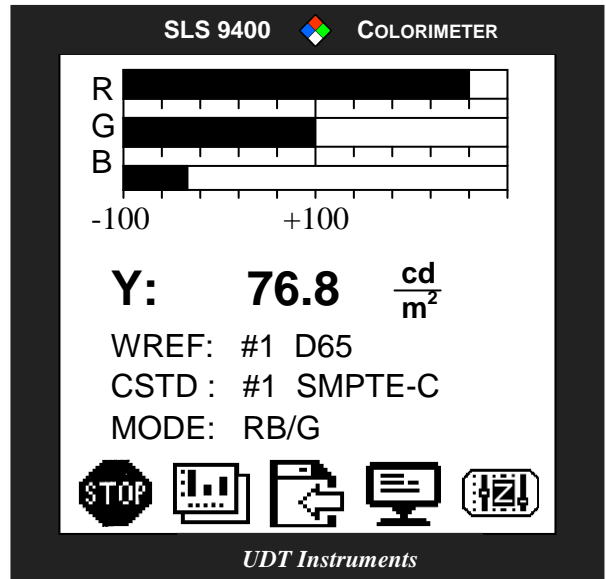

RGB data is calculated per the SMPTE RP 177-1993 using the chromaticity coordinate values corresponding to the selected white reference (WREF:) and Color Standard (CSTD:). These values maybe changed via the WHITE REFERENCE and COLOR STANDARD menu options in the CONFIGURATION 1 menu. The RGB data is available over the RS-232 port in response to the R command while in the RGB display mode. These values are then normalized and displayed based on the selected bar graph mode (MODE:). For selected bar graph mode (MODE:) RG/B, B (blue) is the normalizer and for bar graph mode GB/R, R (red) is the normalizer. As an example, if the selected bar graph mode is RB/G, G (green) is the normalizer, which is held constant, and the R (red) and B (blue) balance is calculated as follows:

$$\bullet \Delta R = \frac{(R_{measured} - R_{ref})}{(G_{measured} - G_{ref})} \times 100\%$$

$$\bullet \Delta G = 0 \quad (\text{The Selected Normalizer})$$

$$\bullet \Delta B = \frac{(B_{measured} - B_{ref})}{(G_{measured} - G_{ref})} \times 100\%$$

In the event, the user has selected a stored measurement as the RGB REFERENCE, the measurement must have been previously stored while in the RGB display mode. With a stored measurement as the RGB REFERENCE, the displayed values will be calculated as follows:

$$\bullet \Delta R = \frac{(R_{measured} - R_{ref})}{R_{ref}} \times 100\%$$

$$\bullet \Delta G = \frac{(G_{measured} - G_{ref})}{G_{ref}} \times 100\%$$

$$\bullet \Delta B = \frac{(B_{measured} - B_{ref})}{B_{ref}} \times 100\%$$

3

The Model SLS 9400 provides manual (see page 21) and automatic RGB bar scaling. In the automatic mode the instrument will automatically adjust the scale of the RGB bars to allow the user to conveniently adjust the colors without having to modify the display resolution. A scale independent numeric readout to the right of each bar will display the actual value of  $\Delta R$ ,  $\Delta G$ , and  $\Delta B$ . The three scaling levels are:

- -100% to 100%
- - 25% to 25%
- - 10% to 10%

When the value of  $\Delta R$ ,  $\Delta G$ , and  $\Delta B$  equals zero, the color balance corresponds to the selected reference. This is indicated when the bars are centered while the RGB scaling is set to the highest resolution ( $\pm 10\%$ ). The RGB measurements are independent of the luminance level.

**NOTE:** The RGB calculations are directly dependent on the White Reference and the Primary Colors of the monitor. To ensure accurate RGB measurements, it is very important that the correct Color Standard is selected via COLOR STANDARD menu option in the CONFIGURATION 1 menu. If the monitor under test does not use one of the pre-programmed Color Standards, then it is necessary to characterize the chromaticity of primary colors used in the monitor. This can be done by the Model SLS 9400's Color Standard learn mode or entered manually if the chromaticity coordinate values are known for the primary colors. For further information see the *SMPTE Recommended Practice, "Derivation of Basic Television Color Equations", RP 177*, for details concerning the proper derivation of RGB data.

**Instrument Operation:**

The Model SLS 9400 is primarily controlled through five icons displayed at the bottom of the screen. To move between the icons use the LEFT and RIGHT arrow keys. To activate the icon function press the ENTER key. To move around in the menus use the LEFT, LEFT, UP, and DOWN keys, and press the ENTER key to activate a menu selection.

**Icons:**

The function of each icon and its associated menus are explained in the following section.

**Stop:**

The stop icon is a toggle switch. When the ENTER key is depressed while the stop icon is highlighted, the instrument will stop performing measurements and enter the hold mode. The stop icon will be replaced with a flashing H icon. When the ENTER key is depressed again, the instrument will resume measuring and the stop icon will be displayed. All menus are available in either mode.

**Display Mode:**

The DISPLAY MODE icon will select between the three display modes. Use the up-down arrow keys to scroll through the available display modes and the ENTER key to select a new mode. The configuration of each mode will depend on the current setup parameters. When the instrument is in the HOLD mode and a new display mode is selected, the instrument will deactivate the HOLD mode and changes to the new measurement mode.

**Save:**

The save icon will display the SAVE menu. This menu allows the user to save the current setup parameters, the current measurement, white reference, or Color Standard chromaticity coordinates, and the state of RS-232 communications.

**View:**

The view icon will display the VIEW menu. This menu allows the user to view the stored Setup, Measurement, White Reference and Color Standard chromaticity coordinates.

**Configuration:**

The configuration icon is used to configure the Model SLS 9400 setup parameters and to view the current status and calibration information. The zoom-configuration icon indicates manual scaling is active (RGB and CIE plot modes). Use the UP and DOWN arrow keys to change the scaling resolution. Press the ENTER key to enter the configuration menu.

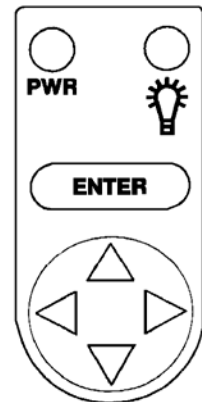

### Menu Options

Use the UP and DOWN arrow keys to scroll through the menus and the ENTER key to select a function. To allow for faster movement within the SAVE, VIEW, and CONFIGURATION menus and sub-menus, the LEFT arrow key positions the cursor at the first menu selection and the RIGHT arrow key moves the cursor to the exit menu selection.

### Save Menu

The SAVE menu is used to store and erase setup parameters, measurement values, white reference values, Color Standard chromaticity values, and change the state of RS-232 communications.

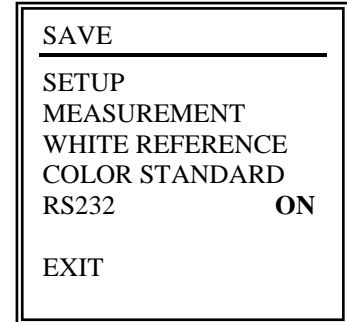

### Save Setup

The SAVE SETUP menu has five available memory locations that can be used to store desired setup parameters. To save a setup, select a memory location and press ENTER. When a memory location is selected, the menu options NAME, SAVE AS #, EXIT, and the current setup information will be displayed. This information consists of:

- Measurement mode
- Luminance units
- Bar graph measurement mode
- White reference
- Color Standard
- Bar graph mode reference
- Differential mode reference

<p><b>SAVE SETUP</b></p> <ol style="list-style-type: none"> <li>1. DEFAULT</li> <li>2.</li> <li>3.</li> <li>4.</li> <li>5.</li> </ol> <p>EXIT</p>	<p><b>SAVE SETUP</b></p> <hr/> <p>NAME: DEFAULT            SAVE AS # 1            EXIT</p> <hr/> <p>CIE 1931 xy            cd/m<sup>2</sup>            RB/G            D65            SMPTE C            RGBREF: W#1            DREF: W#1</p>
---	---

To save a setup, it is first necessary to name the setup memory location. Select NAME and press the ENTER key. The cursor will move to the first character of the name. Using the UP and DOWN arrow keys will change the character, the RIGHT and LEFT arrow keys will move the cursor to the next/previous character field. Press ENTER when the entry is complete. Scroll down to SAVE AS # and press ENTER.

The name of the first memory location is preprogrammed to DEFAULT and cannot be changed. However, the setup parameters can be changed through the configuration menu. The DEFAULT memory location will be used when the instrument is turned on.

A saved setup contains parameters for both the numeric and the bar graph display modes.

To erase a setup, select NAME and press the ENTER key. The cursor will move to the first character of the name. Using the UP and DOWN arrow keys, change the first character to a blank. Press ENTER. The name will be cleared from the display. To complete the erasure, scroll down to SAVE AS # and press ENTER.

The setup in the first memory location is preprogrammed to DEFAULT and cannot be erased. Also the instrument will not allow erasure of the setup currently in use. If an attempt is made to erase a currently used setup, the instrument will display the error message "MEM LOC ERROR".

**Save Current Measurement:**

The SAVE MEASUREMENT menu has nine available memory locations that can be used to store desired measurements. To save a measurement, select a memory location and press ENTER. When a memory location is selected, the menu options NAME, SAVE AS #, EXIT, and the current measurement data will be displayed. The format of the data depends on the measurement mode.

<p style="text-align: center; border-bottom: 1px solid black; margin-bottom: 5px;">SAVE MEASUREMENT</p> <p>1. 2. 3. 4. 5. 6. 7. 8. 9. EXIT</p>	<p style="text-align: center; border-bottom: 1px solid black; margin-bottom: 5px;">SAVE MEASUREMENT</p> <p>NAME: SAVE AS #1 EXIT</p> <p style="text-align: center; margin-left: 100px;">x            y</p> <p style="text-align: center; border-top: 1px dashed black; margin: 5px 0;">-----</p> <p style="text-align: center; margin-left: 100px;">0.3760   0.3890</p> <p>Y:     39.9 cd/m<sup>2</sup> T:     4185 K DE:    57.8</p>
--	---

	Measurement Modes			
	Numeric		CIE plot	Bar
	xy, u'v', ΔxΔy, Δu'Δv'	XYZ	xy, u'v', ΔxΔy, Δu'Δv'	RGB
Measurement Data	✓	✓	✓	✓
Luminance Value	✓		✓	✓
Color Temperature	✓	✓	✓	
ΔE	✓			

To save a measurement, it is first necessary to name the measurement memory location. Select NAME and press the ENTER key. The cursor will move to the first character of the name. Using the UP and DOWN arrow keys will change the character, the RIGHT and LEFT arrow keys will move the cursor to the next/previous character field. Press ENTER when the entry is complete. Scroll down to SAVE AS # and press ENTER. The measurement name in the SAVE MEASUREMENT menu will be displayed along with NUM indicating the measurement was stored in one of the numeric modes or RGB if it was stored in RGB mode.

To erase a measurement, select NAME and press the ENTER KEY. The cursor will move to the first character of the name. Using the UP and DOWN arrow keys, change the first character to a blank. Press ENTER. The name will be cleared from the display. To complete the erasure, scroll down to SAVE AS # and press ENTER.

A measurement cannot be cleared if it is currently used as either a RGB REFERENCE or a DELTA REFERENCE. If an attempt is made to erase a currently used measurement, the instrument will display the error message "MEM LOC ERROR".

### Save White Reference:

The save WHITE REFERENCE menu has six memory locations. The first four memory locations contain the preprogrammed white reference chromaticity coordinates for D65, 9300K D50, D55 and 3200K Standard Illuminants. The remaining two memory locations can be programmed by entering the desired values. The values can be entered as xy or  $u'v'$  chromaticity coordinates. To save a white reference, select a memory location and press ENTER. When a memory location is selected, the menu options NAME, SAVE AS #, EXIT, →, and the current measurement data will be displayed (in xy or  $u'v'$  format).

SAVE WHITE REF	
1.	D65
2.	9300K
3.	D50
4.	D55
5.	3200K
6.	
	EXIT

SAVE WHITE REF	
NAME: D65	
SAVE AS #4	
EXIT	
	x      y
→	0.3127 0.3291

To save a white reference, it is first necessary to name the white reference memory location. Select NAME and press the ENTER key. The cursor will move to the first character of the name. Using the UP and DOWN arrow keys will change the character, the RIGHT and LEFT arrow keys will move the cursor to the next/previous character field. Press ENTER when the entry is complete. Scroll down to SAVE AS # and press ENTER.

The entry chromaticity mode can be selected by changing the measurement mode from the configuration menu. Saving a white reference option is only accessible while the instrument is in the xy and  $u'v'$  modes. The current measurement data is displayed and can be manually modified by scrolling to the menu item → and pressing ENTER key. This will position the cursor on the first character of the chromaticity coordinate. Using the UP and DOWN arrow keys will change the character, the RIGHT and LEFT arrow keys will move the cursor to the next/previous character field. Press ENTER when the entry is complete. Scroll to SAVE AS # and press ENTER.

The white reference chromaticity coordinates are displayed to four decimal places. This is done to prevent round off errors in the calculations. Valid xy coordinates range from 0.0048 to 0.8338 ( $u'v'$ : 0.0159 to 0.6233). The limits have been selected based on tabular data of Table I (3.3.1) Color-Matching Functions and Corresponding Chromaticity Coordinates of the CIE 1931 Standard Colorimetric System, for  $\lambda = 360$  to 830 nm at 1 - nm Intervals in *Color Science: Concepts and Methods, Quantitative Data and Formulae*, second edition, by Wyszecki and Stiles (1982).

**NOTE:** The user must use extreme caution when entering chromaticity coordinates manually. Although the instrument performs a limits check on the entered data, it is possible to enter coordinates that satisfy the limits but provide coordinates outside the define color space when transformed between color spaces. For example, entering  $x$  &  $y = 0.0159$  (the  $u'v'$  lower limit) will pass the  $xy$  limits check, and the instrument will accept and use these values. However, when transformed and viewed in the  $u'v'$  mode these values are not defined within the  $u'v'$  color space.

$$\begin{array}{ll} x = 0.0159 & \rightarrow u' = 0.0061 \\ y = 0.0159 & \rightarrow v' = 0.0453 \end{array}$$

To erase a white reference, select NAME and press the ENTER key. The cursor will move to the first character of the name. Using the UP and DOWN arrow keys, change the first character to a blank. Press ENTER. The name will be cleared from the display. To complete the erasure, scroll down to SAVE AS # and press ENTER.

A white reference cannot be cleared if it is currently used to perform RGB calculations, as a RGB REFERENCE or a DELTA REFERENCE. If an attempt is made to erase a currently used white reference, the instrument will display the error message "MEM LOC ERROR".

#### **Save Color Standard:**

The save COLOR STANDARD menu has six memory locations. The first five memory locations contain the preprogrammed chromaticity coordinates for SMPTE-C, EBU, ITU REC.709, ADOBE RGB, and DCI-P3 Color Standards. (A list of the Color Standards chromaticity coordinates is available in Appendix D). The remaining memory location can be programmed by entering the desired chromaticity coordinates. The values can be entered as  $xy$  or  $u'v'$  chromaticity coordinates. To save a Color Standard, select a memory location and press ENTER. When a memory location is selected, the menu options NAME, SAVE AS #, EXIT, LEARN, R, G, B, and the current measurement data will be displayed for each primary color of the Color Standard.

SAVE COLOR STD	
1.	SMPTE-C
2.	EBU
3.	REC.709
4.	ADOBERGB
5.	DCI-P3
6.	
	EXIT

- Reading R ( $xy, u'v'$ )
- Reading G ( $xy, u'v'$ )
- Reading B ( $xy, u'v'$ )

To save a Color Standard, it is first necessary to name the memory location. Select NAME and press the ENTER key. The cursor will move to the first character of the name. Using the UP and DOWN arrow keys will change the character, the RIGHT and LEFT arrow keys will move the cursor to the next/previous character field. Press ENTER when the entry is complete. Scroll down to SAVE AS # and press ENTER. There are two ways to save a Color Standard: manual entry mode and learn mode.

**Save Color Standard - Manual Entry:**

To modify the chromaticity coordinates of a Color Standard, scroll to the appropriate menu selection and press ENTER. This will position the cursor on the first character of the chromaticity coordinate. Using the UP and DOWN arrow keys will change the character, the RIGHT and LEFT arrow keys will move the cursor to the next character field. Press ENTER when the entry is complete. When all entries are complete scroll to SAVE AS # and press ENTER.

SAVE COLOR STD		
NAME:		
SAVE AS #6		
EXIT		
LEARN		
	x	y
R:	0.3333	0.3333
G:	0.3333	0.3333
B:	0.3333	0.3333

The chromaticity coordinates are displayed to four decimal places. This is done to prevent round off errors in the calculations. Valid xy coordinates range from 0.0048 to 0.8338 ( $u'v'$ : 0.0159 to 0.6233). The entry mode can be selected by changing the measurement mode from the configuration menu. Saving a Color Standard is only accessible while the instrument is in the xy and  $u'v'$  modes.

**NOTE:** The user must use extreme caution when entering chromaticity coordinates manually. Although the instrument performs a limits check on the entered data, it is possible to enter coordinates that satisfy the limits but provide coordinates outside the defined color space when transformed between color spaces. See the *Save White Reference* note on page 15.

**Save Color Standard – Learn Mode:**

To enter the learn mode scroll to LEARN and press ENTER. The user is presented with three menu selections: MEASURE RED, MEASURE GREEN, and MEASURE BLUE. To correctly determine the chromaticity coordinates of each primary color it is necessary to turn on one channel (R, G, or B) at a time and take a corresponding measurement. When the desired channel is on, scroll to the corresponding measurement selection (i.e. if the red channel is on then select MEASURE RED) and press ENTER. The instrument will respond with PROCESSING... to indicate that a measurement is underway. When the measurement is complete, the chromaticity coordinates will be displayed. Repeat for remaining channels (primary colors). Scroll to EXIT and press ENTER. The user is presented with the SAVE COLOR STD menu. It is now possible to save the Color Standard as described above as well as perform manual manipulation of the chromaticity coordinates.

SAVE COLOR STD		
NAME:		
SAVE AS #3		
EXIT		
	x	y
R:		
G:		
B:		
	MEASURE RED	
	MEASURE GREEN	
	MEASURE BLUE	

In the event of an error, the instrument will prompt the user with an appropriate error message. Remedy the problem and repeat the measurements.

To erase a Color Standard, select NAME and press the ENTER key. The cursor will move to the first character of the name. Using the UP and DOWN arrow keys, change the first character to a blank. Press ENTER. The name will be cleared from the display. To complete the erasure, scroll down to SAVE AS # and press ENTER.

A Color Standard cannot be cleared if it is currently used to perform RGB calculations. If an attempt is made to erase a currently used Standard, the instrument will display the error message "MEM LOC ERROR".

**RS232:**

The RS232 is a toggle that turns RS-232 communications on or off. When RS-232 is on, the instrument will enable serial port communications. This configuration flag is stored in non-volatile memory. Upon power up, the instrument will use this flag to set the RS-232 configuration. RS232 should be set to off if the serial port is not needed and conservation of battery charge is a concern.

**View:**

The VIEW menu options allow the user to view stored setups, measurements, white references, and color standards. The format of the view screens is similar to the save menu screens previously described.

**Instrument Configuration (screen 1):**

Instrument configuration is specified using two configuration menus. The CONFIGURATION 1 menu will allow the user to fully specify all setup parameters for the three display modes. The CONFIGURATION 2 menu will allow the user to perform a field calibration, view the calibration information, and allow an authorized user to set the time, date, calibration due date, and more.

CONFIGURATION 1
RECALL SETUP
STATUS
MEASUREMENT MODE
LUMINANCE UNITS
BAR GRAPH MODE
WHITE REFERENCE
COLOR STANDARD
RGB REFERENCE
DELTA REFERENCE
POWER SAVER: ON
NEXT SCREEN
EXIT

**Recall Stored Setup Parameters:**

The RECALL SETUP allows the user to configure the instrument using previously stored setup parameters. When a setup is recalled it will set the:

- Measurement mode
- Luminance units
- Bar graph measurement mode
- White reference
- Color Standard
- Bar graph reference
- Delta reference

**NOTE:** If selecting a setup that utilizes a stored measurement, white reference, or color standard for calculation purposes that no longer exists, the instrument will ignore the setup parameters and default to the parameters of setup #1 (DEFAULT). In the event setup # 1 (DEFAULT) also requires reference parameters that no longer exist the instrument will default to display mode of xyY, D65 as the white reference, and SMPTE-C as the color standard.

**View Current Setup Parameters:**

The STATUS displays the current instrument setup parameters. The display will vary depending on the current display mode.

1. In the CIE plot and numeric display mode STATUS displays:

- MEASUREMENT MODE
- LUMINANCE UNITS
- CALIBRATION TYPE (TYPE)
- NUMBER OF MEASUREMENTS IN AVERAGE
- DELTA REFERENCE (in  $\Delta x\Delta y$  and  $\Delta u'\Delta v'$  modes)
- SETUP #
- POWER SAVER STATUS

STATUS	
MEASUREMENT MODE	
CIE 1931 xy	
UNITS:	Cd/m <sup>2</sup>
TYPE:	FPD-LED
AVERAGING: 8	
SETUP #1	DEFAULT
POWER SAVER	OFF
EXIT	

2. In the RGB bar graph display mode STATUS displays:

- MEASUREMENT MODE
- LUMINANCE UNITS
- CALIBRATION TYPE
- NUMBER OF MEASUREMENTS IN AVERAGE
- RGB REFERENCE
- COLOR STANDARD
- WHITE REFERENCE
- SETUP #
- POWER SAVER

```

STATUS
-----
MEASUREMENT MODE
           RG/B
UNITS: cd/m2
TYPE: FPD-LED
AVERAGING: 8

RGB: W#1 D65
CSTD: #1 SMPTE C
REF: #1 D65
SETUP # DEFAULT

POWER SAVER      OFF
EXIT
    
```

The SETUP #, which is located at the bottom of the screen, displays the name of the memory location of the currently loaded setup. If any of the setup parameters previously set have been changed or erased, the SETUP # will display MODIFIED.

**Set Measurement Mode:**

The MEASUREMENT MODE menu is used to select the desired measurement mode. The available measurement modes are:

- CIE 1931 xyY chromaticity coordinates
- CIE 1976 u'v' Y uniform color space coordinates
- CIE 1931  $\Delta x \Delta y Y$ , the delta measurement is performed with respect to either a stored measurement or a stored white reference
- CIE 1976  $\Delta u' \Delta v' Y$ , the delta measurement is performed with respect to either a stored measurement or a stored white reference
- CIE 1931 XYZ tri-stimulus values.

```

MEASUREMENT MODE
-----
CIE 1931 xy
CIE 1976 u'v'
CIE 1931 dx dy
CIE 1976 du' dv'
CIE 1931 XYZ
EXIT
    
```

**NOTE:** Ideally, the "Y" value in all numeric display modes should be identical. However, the Model SLS 9400 handles (displays) the CIE 1931 XYZ mode's "Y" value differently than the "Y" values displayed in the remaining display modes. Specifically, the "Y" values displayed in all modes other than the CIE 1931 XYZ mode are of the units fL, cd/m<sup>2</sup>, and nits which are based on a luminance calibration. In the CIE 1931 XYZ mode, the "Y" value is based on an illuminance calibration (units of lux). This deviation allows UDT Instruments to maintain direct correlation to the in-house calibration standards. In the event CIE 1931 XYZ values based on luminance are desired, the user need only to mathematically

compensate by scaling the displayed XYZ values to the "Y" value of the remaining modes.

**Luminance Units:**

The LUMINANCE UNITS menu is used to select the photometric units:

- cd/m<sup>2</sup>
- fL
- nt

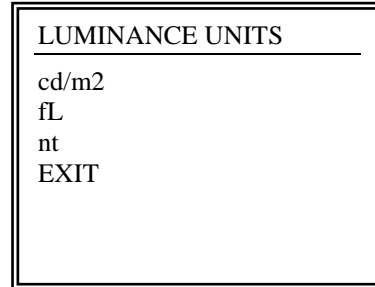

**Bar Graph Mode:**

The BAR GRAPH MODE menu is used to select the normalizer. RB/G, GB/R, and RG/B normalizing modes are only active when a RGB REFERENCE is set to a WHITE REFERENCE.

The RGB bar graph resolution can be set manually or by the instrument automatically. SCALING toggles between AUTO and MAN. In AUTO scaling, the instrument will automatically change the displayed bar graph resolution to provide the optimum resolution of the currently measured color imbalance. When the instrument is in the MAN scaling mode, the display will indicate manual zoom operation by displaying "MAN" between the bar graph limits and the CONFIGURATION icon will change to the ZOOM CONFIGURATION icon. The resolution can be modified by pressing the up and down arrows while the ZOOM CONFIGURATION icon is highlighted.

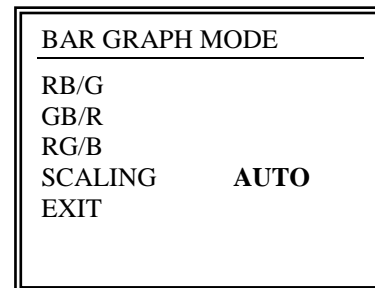

The actual numeric value of ΔR, ΔG, and ΔB are displayed independent of the selected resolution. The bar graph resolution does not affect the data provided via the RS-232 port.

The AUTO RGB scaling is always the default mode when the instrument is powered up.

**White Reference:**

The WHITE REFERENCE menu is used to select the desired white reference. This is necessary to perform accurate RGB measurements.

**Color Standard:**

The COLOR STANDARD menu is used to select the current color standard. This is necessary to perform accurate RGB measurements.

**RGB Reference:**

The RGB REFERENCE menu is used to select the reference type used to display the RGB bar graphs. There are two types of references available; either a previously stored measurement (stored in RGB mode) or a white reference. When selecting a measurement as the reference, the bar graphs will be calculated as described previously for delta R, G, and B. Using a white reference as the reference R, G, and B will be calculated using the selected normalizer previously described.

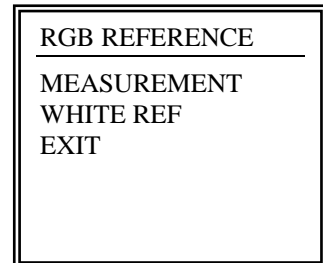

Upon selection of MEASUREMENT the instrument will prompt for the selection of a previously stored RGB measurement. The instrument will then calculate and display delta R, G, and B. In the bar graph display mode, the REF: will indicate M# <NAME>, CSTD: will be blank and MODE: will indicate RGB/RGB. If an incorrectly stored measurement is selected, the instrument will ignore this selection, and display an error message.

Upon selection of WHITE REFERENCE the instrument will use the same white reference chromaticity coordinates to calculate RGB values and displays them per the previously selected bar graph mode. In the bar graph display mode, the **MODE:** will indicate the previously selected bar graph mode and the REF: will indicate W# <name>, and CSTD: will indicate the Color Standard selected in the CONFIGURATION menu.

**Delta Reference:**

The DELTA REFERENCE menu is used to select the reference type chromaticity coordinates to be used to calculate the difference between a current reading and a stored reading. There are two types of references available; either a previously stored measurement (stored in NUM mode) or a white reference. Upon selection of a reference, the chromaticity coordinates will be retrieved and used to perform the  $\Delta x \Delta y$  or  $\Delta u' \Delta v'$  (based on MEASUREMENT MODE selection), and  $\Delta E$  calculations.

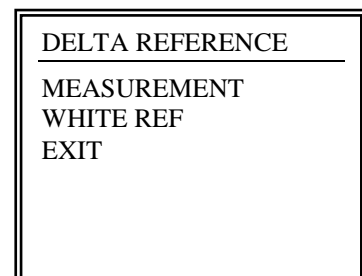
**Power Saver:**

POWER SAVER is a toggle that turns the power saver on or off. When the power saver is on, the instrument will automatically turn off approximately in 10 minutes after the last key is pressed or serial port command is received.

**Next Screen:**

NEXT SCREEN brings the user to the second configuration menu labeled CONFIGURATION 2.

**Instrument Configuration (screen 2):**

Instrument configuration 2 menu allows the user to view which type of display (CRT or FPD) calibrations are programmed in the instrument, view the system calibration information (serial numbers; dates & software revision) and other functions explain in detail below

```

CONFIGURATION 2
-----
RECAL REF.
CAL TYPE: FPD-CCFL
AVERAGING 4
CALIBRATION INFO
SET DATE
SET TIME
EMULATION OFF
EXIT
  
```

**Recal Ref:**

RECAL REF. (recalibrate reference) is used when the SLS 9400 displays a different value than what is predicted from a “known” source. For example, a display manufacturer sets up a master display to what is believed by the manufacturer to have x and y chromaticity values of .300 and .300, a luminance of 100 cd/m<sup>2</sup>, and a CCT of 15,000K. Since the manufacturer wants all other displays in the factory to match the master, the SLS 9400 should display the above values when a new display matches the master. To achieve this goal, the manufacturer must perform a field calibration (i.e. recalibrate the reference).

```

RECAL REF.
-----
SET x
SET y
SET Y
SET T
COMPUTE
EXIT

x 0.300
y 0.300
Y 100.0
T 15000
  
```

A field calibration is performed by following these steps:

1. From the main screen (which is the first screen seen when the SLS 9400 is powered up), go to the configuration menu. This is done by selecting the icon at the far right.
2. The SLS 9400 should now be displaying the first configuration screen where CONFIGURATION 1 is written across the top of the screen.
3. Select next screen. This option is the next to last option.
4. The SLS 9400 should now be displaying the second configuration screen where CONFIGURATION 2 is written across the top of the screen.
5. Select RECAL REF.. This is the first option.
6. The SLS 9400 should now be displaying the reference recalibration screen RECAL REF. is written across the top of the screen. From this screen, it is possible to recalibrate x, y, Y, and/or T.
7. Choosing one variable at a time, select the variable to be changed. When a variable is selected, a cursor will appear over the first digit of that variable near the bottom of the screen. Use the left and right arrow keys to move the cursor, and use the up and down arrow keys to change the digits. Press the enter key when finished editing a variable.
8. When all known values are entered, hold the SLS 9400 head piece to the display and select compute. The SLS 9400 will display a calculation message. Keep the head piece against the display until the SLS 9400 is finished calculating. The CONFIGURATION 2 screen will then be displayed.
9. Finally, make sure that the emulation mode, which can be seen in the

CONFIGURATION 2 menu, is ON.

10. Exit the configuration 2 menu and begin taking measurements.

**NOTES:**

- The RECAL REF. screen has a key debounce feature. Once a variable has been selected to edit, pressing ENTER again will not allow the user to leave the editing mode until another key is pressed.
- The values of the variables in the RECAL REF. screen do not get saved until COMPUTE is selected.
- Sometimes it is desirable to calculate some variables, but not others. For example, one may wish to recalibrate only the x and y values but not the Y and T values. For variables that are not to be recalibrated, set those values to 0 in the RECAL REF. menu.

**Cal Type: CRT / FPD**

This menu allows to view pre-programmed calibration matrixes and select active matrix which will be used for color and luminance calculations. The active matrix will be highlighted upon entry into this menu. The instrument will retain the selected active matrix upon power cycling. Up to five independent color / luminance calibration matrixes can be stored in the non-volatile memory of the instrument.

CRT / FPD SELECT
1. CRT
2. FPD-CCFL
3. FPD-LED
4. CUSTOM-1
5.
EXIT

**Averaging:**

This parameter specifies how many A/D readings in the Optical Detector Head to be averaged by the microprocessor for each color/luminance calculation. It can be set in the range 1 to 16 (1, 2, 4, 8, and 16). In order to change the setting of averaging, select menu item AVERAGING and keep pressing the ENTER key until the desired averaging parameter is selected. Switch to another menu item by using UP or DOWN keys in order to preserve the selected setting of averaging.

**Calibration Info:**

The CALIBRATION INFO displays the following:

- SERIAL NUMBER (Handheld#/Optical Detector Head#)
- REV LEVEL (Firmware revision)
- CAL REPORT (Calibration Report #)
- LAST CALIBRATION (date)
- CALIBRATION DUE (date)

CALIBRATION INFO
SERIAL NUMBER 8A029 / 8A029
REV LEVEL D7
CAL REPORT 90020
LAST CALIBRATION 04-16-2009
CALIBRATION DUE 10-16-2009
EXIT

***Time and date settings:***

The handheld portion of the SLS 9400 contains a real time clock (RTC) circuit which is set at the factory. It is necessary to keep track of the time and date so that the user can be reminded when the SLS 9400 is to be sent back to the factory for recalibration. The time and date setting features allow an authorized user to:

ENTER PASSWORD  
OR PRESS ENTER  
TO EXIT

- set the time in the RTC
- set the date in the RTC
- set the calibration due date

These features are password protected and require written authorization from UDT Instruments before these parameters may be changed in the field. If either of these options is chosen, the user is presented with a message to enter the password. If an incorrect password is entered, program control is passed back to the CONFIGURATION 2 menu.

***Emulation mode:***

Emulation mode is set in the CONFIGURATION 2 screen. The following best summarizes this feature:

- When emulation mode is ON, the field calibration is in effect.
- When emulation mode is OFF, the SLS 9400 uses factory set calibration.

## RS-232 Serial Communication Parameters and Commands

### Introduction:

All instrument features are accessible via the RS-232 serial port (the RS-232 option must be in ON state, see page 12).

The communication protocol over the RS-232 port is defined in the *Electronic Industries Alliance (EIA) standard RS-232-C*.

### Connection Diagram:

The following diagram describes connection of SLS 9400 Colorimeter equipped with 6-position Modular Jack (RJ) to a Personal Computer equipped with DB9 Serial Port Connector.

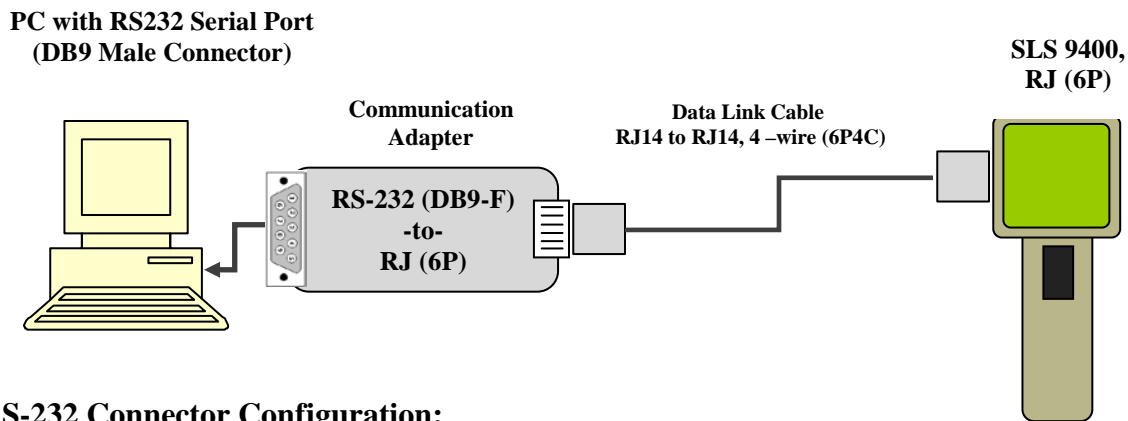

### RS-232 Connector Configuration:

The following table describes the standard pin configuration of DB9 RS-232 port (as defined in EIA/TIA-574) and signals supported by RS-232-to-RJ Communication Adapter. Note, that only three standard signals (TD, RD, and SGND) are utilized to support the serial port communication between PC and SLS 9400 Colorimeter.

See Table below for pin assignments in RS232-to-RJ communication adapter.

Pin	Signal Name	Description	Support
1	CD	Carrier Detect	Not Connected
2	RD	Receive Data (RxD)	to RJ, position 3
3	TD	Transmit Data (TxD)	to RJ, position 4
4	DTR	Data Terminal Ready	Not Connected
5	SGND	Signal Ground	to RJ, position 5
6	DSR	Data Set Ready	Not Connected
7	RTS	Request To Send	Not Connected
8	CTS	Clear To Send	Not Connected
9	RI	Ring Indicator	Not Connected

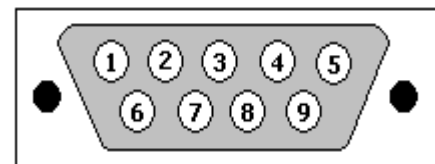

DB9 Male Connector, Front View

**RJ14 Standard wiring of Data Link Cable (6-position RJ plug, both ends, 4-wire):**

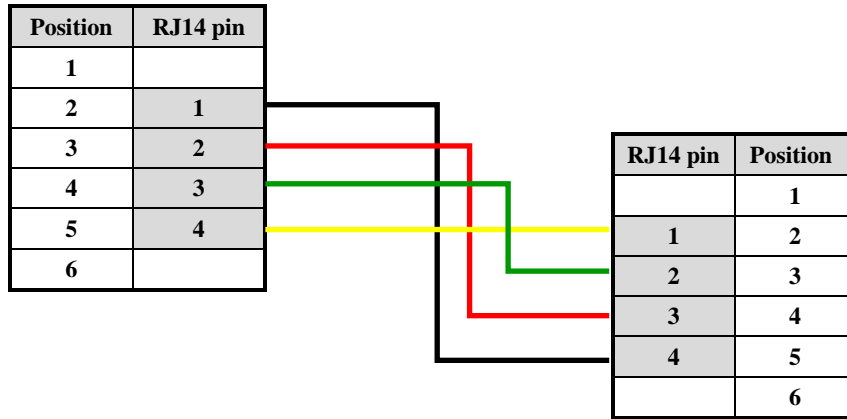

**Pin Assignments on RJ Connector (Jack, SLS 9400 side):**

Pin Position	Signal Description	Application
1	VCC (+5 VDC)	Do Not Use!
2	Signal Ground	Connected
3	Receive Data	Connected
4	Transmit Data	Connected
5	-	Not Connected
6	VCC AUX (+5VDC)	Do Not Use!

6-position jack, Front View

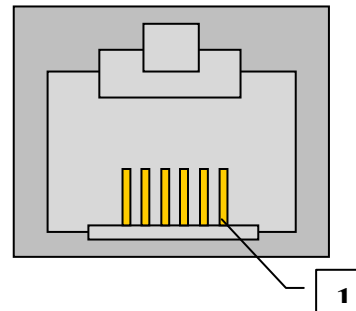

**Communication Protocol:**

To ensure proper communication with the Model SLS 9400 via the RS-232 serial port, the computer's communication parameters must be configured to match the communication parameters of the Model SLS 9400.

The default communication parameters are:

- |             |      |
|-------------|------|
| ▪ Baud Rate | 9600 |
| ▪ Parity    | None |
| ▪ Data Bits | 8    |
| ▪ Stop Bits | 1    |

Upon entering a valid command, the instrument will disable further serial port reception, perform the command, and return the appropriate information. All commands sent from the computer, through the RS-232 port, need to be upper case ASCII character strings terminated by a carriage return (ASCII 13) and a linefeed (ASCII 10); i.e. **R <CR><LF>**. As a minimum, the instrument will always respond with five status bytes followed by a CR and LF characters. Depending on the command, the status information may be prefixed by command response data. After this command/response cycle has been completed, the instrument will be available to process a new command. **Therefore, the user should wait for the response to the previous command before sending a new one.**

**NOTE:** To ensure proper operation, verify that the instrument is in one of the measurement display modes before issuing a RS-232 command.

The serial port commands and the keypad functions are interrelated. For example, if the instrument has been placed in the HOLD mode via the keypad and the serial port receives a UNITS command (i.e. **U0 <CR><LF>**), the instrument will change the luminance units to  $\text{cd/m}^2$  and remain in the HOLD mode.

**Support of virtual Serial Ports created by USB-to-RS232 Converters:**

The SLS 9400 Colorimeter has been tested and worked reliably with the following USB-to-RS232 port converters:

- USB2.0 to 2-port Serial RS-232 Converter model GUC2322, MFG: IOGEAR
- Keyspan High-Speed USB Serial Adapter Model USA-19HS, MFG: TRIPPLITE

**Command Nomenclature:**

- # Storage location for retained Calibration matrixes, setups, measurements, white references, and color standards. The valid range of values for storage location (#) depends on the type of data entity to be accessed (see table below).

STORAGE TYPE	VALID RANGE
Calibration Matrix	1 - 5
Setup Information	1 - 5
Color Standard	1 - 6
White Reference	1 - 6
Reference Measurement	1 - 9

An attempt to access a memory location which does not contain proper data will result in an invalid command.

- <name> Name assigned to the retained storage location. The name must consist of at least one valid character and cannot exceed eight. The valid characters are A →Z, 0 →9, space ( ^ ) and underscore ( \_ ).

**Return Values:**

Most of the commands return the Colorimeter Status Information bytes except where noted.

**Commands:**

A summary of the RS-232 commands is located in Appendix A.

**Readings Averaged: ANx**

Sets the number of A/D readings to be averaged per channel to create a color measurement. The number of averages is calculated as  $2^x$  where valid values of  $x$  range from 0 to 4. On power up, the number of averages is set to 1 ( $2^0$ ). The instrument accumulates  $x$  number of readings before proceeding to the next channel. After all four channels have been measured, the instrument then calculates the appropriate color coordinates. For values of  $x$  greater than one, the instrument's response times will increase from those listed in Appendix A.

Returned value: Status

**Bar Graph Mode: BMx**

Selects the bar graph mode normalizer. This command will select the parameter to be used as the normalizer only when RGB REFERENCE is set to a WHITE REFERENCE. Color balance in the RGB display mode is displayed relative to the selected normalizer. The  $x$  represents an integer value that corresponds to the desired reference value. The available reference values are:

- Green                    0
- Red                      1
- Blue                     2

Returned value: Status

**RGB Reference; White Reference: BR0**

Commands the instrument to use the same white reference selected for the RGB calculation as the bar graph reference mode.

Returned value: Status

**RGB Reference; Measurement: BR1,#**

Selects a desired stored measurement to be used as the reference in the bar graph mode. If a vacant measurement is selected the command will be ignored and return measurement vacant. If an incorrectly stored measurement is selected, the instrument will ignore this selection and return an error.

Returned value: Status





**Display Mode:****DMx**

Changes the display mode between numeric display mode and bar graph mode. The x represents an integer value that corresponds to the desired display mode. The available display modes are:

- Numeric                    0
- Bar                            1

NOTE: The CIE plot mode cannot be selected via RS-232.

Returned value: Status

**Delta Reference:****DRy,#**

Selects the desired memory location, of either a stored measurement or white reference to be used as the reference in the delta mode ( $\Delta x\Delta y$ ,  $\Delta u'\Delta v'$ ). The y represents an integer value that corresponds to the desired reference type. The available reference types are:

- Measurement            0
- White reference        1

Returned value: Status

**Query Stored Setup:****E?#**

Instructs the Model SLS 9400 to send the information stored in setup #.

Returned value:

The information will be returned in the following fixed format:

- Name                                    xxxxxxxx,
- Chroma mode                            x,                                    0: xy, 1: u'v', 2:  $\Delta x\Delta y$ , 3:  $\Delta u'\Delta v'$ , 4: XYZ
- Luminance units                        x,                                    0: cd/m<sup>2</sup>, 1: f L, 2: nt
- Display mode                            x,                                    0: numeric, 1: bar
- RGB mode                                x,                                    0: RB/G, 1: GB/R, 2: RG/B
- RGB reference type                    x,                                    W: white reference, M: measurement
- RGB Reference #                        xx,

*(Continued on the next page)*

- |                     |       |                                    |
|---------------------|-------|------------------------------------|
| ▪ White reference # | xx,   |                                    |
| ▪ Color Standard #  | xx,   |                                    |
| ▪ Delta reference   | x,    | W: white reference, M: measurement |
| ▪ Delta reference # | xx    |                                    |
| ▪ Space             | x     |                                    |
| ▪ Status            | xxxxx |                                    |
| ▪ CRLF              | xx    |                                    |

***Erase Stored Setup:*** ***EC#***

Instructs the Model SLS 9400 to erase the information stored in setup #. Setup memory location 1 and the currently used setup cannot be erased, and an attempt to do so will result in an invalid command.

Return value: Status

***Save Current Instrument Setup:*** ***ES#,<name>***

Instructs the Model SLS 9400 to save the current instrument parameters in the specified setup memory location # as <name> .

The name of memory location 1 cannot be changed from its preprogrammed value (**DEFAULT**). If a setup is saved to setup memory location #1, a name is still required but will be ignored. The previously stored setup parameters will be overwritten with new values.

Return value: Status

***Implement Stored Setup #:*** ***EI#***

Instructs the Model SLS 9400 to implement the stored setup parameters in the specified setup memory location #.

Returned value: Status

***Query Stored Measurement #:*** ***F?#***

Instructs the Model SLS 9400 to send the information stored in measurement #.

*(Continued on the next page)*

Returned value:

The information will be returned in the following fixed format:

- Name xxxxxxxx,
- Chroma mode x, 0: xy, 1: u'v', 2:  $\Delta x\Delta y$ , 3:  $\Delta u'\Delta v'$ , 4: XYZ
- Luminance units x, 0:  $\text{cd/m}^2$ , 1: f L, 2: nt
- Display mode x, 0: numeric, 1: bar
- RGB mode x, 0: RB/G, 1: GB/R, 2: RG/B
- RGB reference type x, W: white reference, M: measurement
- RGB Reference # xx,
- White reference # xx,
- Color Standard # xx,
- Delta reference x, W: white reference, M: measurement
- Delta reference # xx
- Measurement (see tables below)
- Space x
- Status xxxxx
- CRLF xx

The measurement values returned will depend on the chromaticity mode and the display mode of the instrument when the measurement was stored.

Reading format for chroma modes 0 thru 3 in the numeric display & CIE plot mode:					
	Reading 1	Reading 2	Reading 3	Reading 4	Reading 5
Format	xxxxxxx,	xxxxxxx,	xxxxx,	xxxxx,	xxxxx
Mode xy	x	y	Y	T	$\Delta E$
Mode u'v'	u'	v'	Y	T	$\Delta E$
Mode $\Delta x\Delta y$	$\Delta x$	$\Delta y$	Y	T	$\Delta E$
Mode $\Delta u'\Delta v'$	$\Delta u'$	$\Delta v'$	Y	T	$\Delta E$

(Continued on the next page)

Reading format for chroma mode 4 in the numeric display mode:					
	Reading 1	Reading 2	Reading 3	Reading 4	Reading 5
Format	xxxxxx,	xxxxxx,	xxxxxx,	xxxx,	xxxxx
Mode XYZ	X	Y	Z	--	T

Reading format for bar graph display mode:					
	Reading 1	Reading 2	Reading 3	Reading 4	
Format	xxxxxx,	xxxxxx,	xxxxxx,	xxxxx	--
Bar Mode	R	G	B	Y	--

**Erase Stored Measurement:** *FC#*

Instructs the Model SLS 9400 to erase the information stored in measurement #. A measurement cannot be erased if it is currently used as either a RGB REFERENCE or a DELTA REFERENCE. If an attempt is made to erase a currently used measurement an invalid command will result.

Return value: Status

**Save Current Measurement:** *FS#,<name>:*

Instructs the Model SLS 9400 to save the current chromaticity coordinates in specified measurement memory location # as <name>.

Return value: Status

**Start Measurements:** *G*

Deactivates **HOLD** mode and starts taking measurements.

Return value: Status

***Halt Measurements:*** *H*

Halts the measurement mode.

Return value: Status

***Keypad Disable/Enable:*** *Kx*

Disables/Enables the instrument keypad. When disabled the icons will not be displayed on the screen and all the keys on the keypad will be inactive except the PWR switch.

- Keypad active           0
- Keypad locked out    1

Return value: Status

When the display is disabled, this command will always return an invalid command status.

***Backlight Control:*** *Lx*

Controls the backlight.

- On                    1
- Off                   0

Return value: Status

***Chromaticity Mode:*** *Mx*

Sets the chromaticity mode while the instrument is in the numeric display mode. The x represents an integer value that corresponds to the desired mode. The available display modes are:

- x, y, Y, T & ΔE           0
- $u'$ ,  $v'$ , Y, T & ΔE       1
- Δx, Δy, Y, T & ΔE       2
- Δ $u'$ , Δ $v'$ , Y, T & ΔE     3
- X, Y, Z, -- & T           4

Return value: Status

**Query Stored Color Standard:** *N?#,y*

Instructs the Model SLS 9400 to send the information stored in Color Standard #, in xy ( $y = 0$ ) or  $u'v'$  ( $y = 1$ ) chromaticity coordinates. The information will be returned in the following format:

Return value:

The information will be returned in the following fixed format:

▪ Name	xxxxxxxx,
▪ x/u' RED	0.xxxx,
▪ y/v' RED	0.xxxx,
▪ x/u' GREEN	0.xxxx,
▪ y/v' GREEN	0.xxxx,
▪ x/u' BLUE	0.xxxx,
▪ y/v' BLUE	0.xxxx
▪ Space	x
▪ Status	xxxxx
▪ $C_{R}L_{F}$	xx

**Erase Stored Color Standard***Error! Bookmark not defined.:* *NC#*

Instructs the Model SLS 9400 to erase the information stored in Color Standard #. Color Standard memory locations 1 -4 and the currently used Color Standard cannot be erased, and an attempt to do so will result in an invalid command.

Return value: Status

**Implement Stored Color Standard:** *NI#*

Instructs the Model SLS 9400 to retrieve the Color Standard chromaticity coordinates specified in memory location # for use in calculating RGB values.

Returned value: Status

**Download Color Standard:****ND#,y,D**

Sends to the SLS 9400 all the necessary parameters to describe a Color Standard and store them in the specified memory location #. Where # represents the memory location 5 - 6, and y determines how the chromaticity coordinates are interpreted by the instrument, either xy (y = 0) or  $u'v'$  (y = 1). The data (D) needs to be in the following format:

- Name <name>,
- x/u' RED 0.xxxx,
- y/v' RED 0.xxxx,
- x/u' GREEN 0.xxxx,
- y/v' GREEN 0.xxxx,
- x/u' BLUE 0.xxxx,
- y/v' BLUE 0.xxxx

Valid xy coordinates range from 0.0048 to 0.8338 ( $u'v'$ : 0.0159 to 0.6233).

**NOTE:** The user must use extreme caution when downloading chromaticity coordinates manually. Although the instrument performs a limits check on the entered data, it is possible to enter coordinates that satisfy the limits but provide coordinates outside the define color space when transformed between color spaces. See the *Save White Reference* note (page 15).

Return value: Status

**Turn Instrument Off: 0**

Turns the Model SLS 9400 off.

Return value: None

**Power Saver: Px**

Enables/Disables the power saver mode.

- On 1
- Off 0

Return value: Status

**Query Instrument Info & Calibration Info: Q**

Queries the instrument for its model number, Handheld serial number, head serial number, software revision, and calibration information.

Return value:

- Instrument model 9400,
- Handheld S/N xxxxx,
- Head S/N xxxxx,
- Rev level xx,
- Cal Report xxxxx,
- Last calibration (mm-dd-yy) xx-xx-xxxx,
- Calibration due xx-xx-xxxx
- Space x
- Status xxxxx
- C<sub>R</sub>L<sub>F</sub> xx



If the instrument is in the over range or under range condition only the status is returned.

Continuous REQUEST READING (R Command) execution may not allow the display to update.

***Request Instrument Status:*** *S*

Instructs the Model SLS 9400 to send the status bytes.

Return value: Status

***Set Luminance Units:*** *Ux*

Sets the luminance units of measurement. The x represents an integer value that corresponds to the desired luminance units.

- cd/m<sup>2</sup>        0
- f L            1
- nt             2

Return value: Status

***Query Stored White Reference:*** *W?#,y*

Instructs the Model SLS 9400 to send the information stored in white reference #, either in xy (y = 0) or *u'v'* (y = 1) chromaticity coordinates. The information will be returned in the following format:

Return value:

- Name                    xxxxxxxx,
- x/u'                    0.xxxx,
- y/v'                    0.xxxx
- Space                    x
- Status                    xxxxx
- C<sub>R</sub>L<sub>F</sub>                    xx



**Save Current Measurement as a White Reference:**

*WS#,<name>*

Instructs the Model SLS 9400 to save the current measurement as a white reference in memory location # as <name>. Where # can be 5 or 6.

Return value: Status

**Return Status Information:**

Return Status Information consists of five bytes, a carriage return (ASCII 13) and linefeed (ASCII 10).

*(Continued on the next page)*



**Overall Error:**

Overall error indicator. This status will be set to 1 when any of the invalid status indicators are true or the unit is in the over-range or under-range condition.

**Cal Expired:**

This status (1) indicates that the instrument is out of calibration.

**Invalid Command:**

This status (1) indicates that the Model SLS 9400 received an invalid command. Typical invalid commands consist of an improper format, excluded \_ or a command that is not recognized.

**Backlight:**

This status indicates whether the backlight is **ON** (1) or **OFF** (0).

**Ovrange:**

This status (1) indicates that the Model SLS 9400 is in the over-range condition. An over-range condition indicates an excessive signal level.

The Model SLS 9400 will automatically attempt to correct the over-range condition. The time necessary to correct the over-range condition will depend on the signal level. Once the over-range condition is corrected, the next status sent will indicate that the instrument is no longer in the over-range condition. When the Model SLS 9400 is in the over-range condition and a reading is requested, the instrument will only transmit the status.

**Underrange:**

This status (1) indicates that the Model SLS 9400 is in the under-ranged condition. An under-range condition indicates that there is not enough signal to perform an accurate measurement. The time necessary to correct the under-range condition will depend on the signal level. Once the under-range condition is corrected, the next status sent will indicate that the instrument is no longer in the under-range condition.

When the Model SLS 9400 is in the under-range condition and a reading is requested, the instrument will only transmit the status information.

**Power Saver:**

This status indicates whether the power saver is **ON** (1) or **OFF** (0) .

**Bar Graph Mode:**

This status indicates which parameter is being used as the normalizer in the bar graph mode. The valid normalizer values are:

- Green 0
- Red 1
- Blue 2
- RGB / RGB 3

**Reference Option:**

This status indicates whether a stored measurement (0) or a stored white reference (1) is being used as a reference reading in the bar graph mode or the  $\Delta x \Delta y$  ( $\Delta u' \Delta v'$ ) modes.

**Reference Reading:**

This status indicates which memory location is being used as a reference value based on the *Reference Option*.

**Display Disable:**

This status indicates whether the display and keypad are enabled (0) or disabled (1).

**Hold:**

This status (1) indicates that the Model SLS 9400 is in the HOLD mode.

If a reading is requested while the Model SLS 9400 is in the HOLD mode the previous reading will be sent and this reading will continue to be sent upon request until the unit is returned to the measurement mode.

**Display Mode:**

This status indicates the display mode.

- Numeric 0
- Bar 1

**Keypad Lockout:**

This status indicates the status of the keypad.

- Keypad active           0
- Keypad locked out    1

**Chroma Mode:**

This status indicates the numeric display mode.

- x, y, Y, T &  $\Delta E$            0
- $u'$ ,  $v'$ , Y, T &  $\Delta E$            1
- $\Delta x$ ,  $\Delta y$ , Y, T &  $\Delta E$        2
- $\Delta u'$ ,  $\Delta v'$ , Y, T &  $\Delta E$        3
- X, Y, Z, Y & T           4

**Luminance Units:**

This status indicates the luminance units used.

- $\text{cd/m}^2$                    0
- f L                         1
- nt                         2

**Handheld Not Calibrated:**

This status (1) indicates that the indicator unit is not calibrated. This flag is used for UDT Instruments calibration purposes. If at any time this status is a 1 (TRUE) contact UDT Instruments for assistance.

**Head not Calibrated:**

This status (1) indicates that the detector head is not calibrated. This flag is used for UDT Instruments calibration purposes. If at any time this status is a 1 (TRUE) contact UDT Instruments for assistance.

**Color Standard Vacant:**

This status (1) indicates that the Color Standard memory location, selected using the *N?* or the *NI* commands, does not contain any information.

**White Reference Vacant:**

This status (1) indicates that the white reference memory location, selected using the *W?*, *WI*, *DR* or the *BR* commands, does not contain any information.

**Measurement Vacant:**

This status (1) indicates that the measurement memory location, selected using the *F?*, *DR*, or the *BR* commands, does not contain any information.

**Setup Vacant:**

This status (1) indicates that the setup memory location, selected using the *E?* or the *EI* commands, does not contain any information.

**White Reference:**

This status indicates which white reference memory location is being used in the calculation of RGB values.

**Color Standard:**

This status indicates which COLOR STANDARD memory location is being used in the calculation of RGB values.

Appendix B contains several C functions and several sample status responses illustrate communications with the Model SLS 9400 and determine the current instrument status.

## **Maintenance**

This instrument has no user serviceable parts. If the unit is in need of repair, follow the instructions in the Product Warranty and Return Procedures which can be found in Appendix D.

Use a soft damp cloth to clean the instrument. Do not use alcohol, acetone or any other chemical solvents. Special care must be taken when cleaning the display window. Failure to do so may damage the anti-glare coating.

## **Appendix A**

### **Model SLS 9400 RS-232 Commands and Command Execution Times**

### Model SLS 9400 RS-232 Commands: Summary

Command*	Description	# Bytes Ret
ANx	A/D readings to be averaged per channel (2 <sup>x</sup> )	7
BMx	Bar graph mode (0 /G, 1 /R, 2 /B)	7
BR0	Uses the selected white reference to perform RGB calculations	7
BR1,#	Uses a stored measurement as a reference in the RGB mode, # [1 - 9] represents memory location )	7
CS	Return Calibration Matrix	16
C-	Change Matrix to lower number	16-27
C+	Change Matrix to higher number	16-27
C#	Change Matrix to the specified number	16-27
DDx	Display Disable (0 off, 1 on)	7
DMx	Display Mode (0 numeric, 1 bar)	7
DRy,#	Delta Mode reference reading (y [0 - 1] represents either a stored reading or white ref, # represents memory location, See Table on page 29)	7
E?#	Requests stored setup # [1 -5]	40
EC#	Clears stored setup # [2 - 5]**	7
ES#,<name>	Save current setup # [1 - 5] using <name> (on # = 1, <name> is ignored)	7
EI#	Implement stored setup # [1 - 5]	7
F?#	Requests stored measurement # [1 - 9]	72
FC#	Clears stored measurement # [1 - 9]	7
FS#,<name>	Save current measurement to memory # [1 - 9] using <name>	7
G	Start measurement mode	7
H	Halt measurement mode	7
Kx	Keypad lockout (0 active, 1 inactive)	7
Lx	Backlight (0 off, 1 on)	7
Mx	Chroma mode (0 xy, 1 u'v', 2 ΔxΔy, 3 Δu'Δv', 4 XYZ)	7
N?#,y	Requests stored Color Standard # [1 - 6] (y represents mode (0: xy 1: u'v'))	58
NC#	Clears stored Color Standard memory location # [4 - 6]	7
NI#	Implement stored Color Standard # [1 - 6]	7
ND#,y,D	Download Color Standard data and store in mem # [5 or 6], (y represents mode (0: xy / 1: u'v'), D represents the data***)	7
O	Turns the Model SLS 9400 off.	0
Px	Power saver (auto shut down) (0 off, 1 on)	7
Q	Query instrument	55
R	Send current reading (numeric / RGB)	39 / 46
S	Send status	7
Ux	Set photometric units ( 0 cd/m <sup>2</sup> , 1 fL, 2 nt)	7
W?#,y	Requests stored white reference # [1 - 6] (y represents mode (0: xy/1: u'v'))	30
WC#	Clears stored white reference memory location # [5 or 6]	7
WI#	Implement stored white reference # [1 - 6]	7
WD#,y,D	Download white reference data and store in mem # [5 or 6] (y represents mode (0: xy / 1: u'v'), D represents the data***)	7
WS#,<name>	Save current reading as a white ref to memory # [4 - 9] using <name>	7
*	All commands must be followed by <CR><LF>	
**	Can not clear currently used setup memory location	
***	See command description for data format.	

### Model SLS 9400 Command Execution Times (ms)

Command	Description	Disp On	Disp Off
ANx	A/D readings to be averaged per channel	175	175
BMx	Bar graph mode	650	60
BR0	Change white reference used to perform RGB calculations	230	165
BR1,#	Use a store measurement as a reference in the RGB mode	230	165
CS	Return Calibration Matrix	250	200
C-	Change Matrix to lower number	350	270
C+	Change Matrix to higher number	350	270
C#	Change Matrix to the specified number	350	270
DDx	Display Disable	320	180
DM0	Display Mode	430	75
DM1	Display Mode	610	210
DRy,#	Delta Mode reference reading	270	155
E?#	Request stored setup	260	80
EC#	Clear stored setup	390	330
ES#,<name>	Save current setup	770	605
EI#	Implement stored setup	265	155
F?#	Request stored measurement	280	135
FC#	Clear stored measurement	450	100
FS#,<name>	Save current measurement	2180	2180
G	Start measurement mode	300	55
H	Halt measurement mode	180	110
K0	Keypad lockout (off)	440	---
K1	Keypad lockout (on)	200	---
Lx	Backlight	150	55
Mx	Chroma mode	270	175
N?#,y	Request stored Color Standard	285	275
NC#	Clear stored Color Standard memory location	425	275
NI#	Implement stored Color Standard	247	165
ND#,y,D	Download Color Standard data	1160	1160
Px	Power saver	175	175
Q	Query instrument	300	115
R	Send current reading (Numeric)	329	304
R	Send current reading (RGB)	329	282
S	Send status	180	100
Ux	Set photometric units (Numeric)	250	180
W?#,y	Request stored white reference	275	115
WC#	Clear stored white reference memory	385	360
WI#	Implement stored white reference	230	165
WD#,y,D	Download white reference data	680	580
WS#,<name>	Save current reading as a white ref	935	935

**NOTE:** The times listed are average values. Actual execution is dependent on program flow and interrupt latency. This table was created while the number of averages was set to one.

## **Appendix B**

### **Model SLS 9400 Sample "C" Functions & Status**

```

char crlf[3]; /* carriage return / linefeed termination characters */
int fileId; /* open file id */

/* This function will set the Model SLS 9400 to numeric display mode, xyY measurement mode and perform a /*
/* measurement. The measurement will be parsed and stored in a structure named DATA. */

void main(void){
    char wrtBuf[6]; /* string to store SLS 9400 command */
    char rdBuf[80]; /* string to store returned value from COM port */

    int cnt; /* loop counter */

    struct { /* defining data structure */
        double x; /* chromaticity coordinate x value */
        double y; /* chromaticity coordinate y value */
        double Y; /* luminance value */
        int T; /* correlated color temperature value */
        double Delta_E; /* ΔE (CIELUV) value */
    }data; /* structure name */

    crlf[0] = 13; /* decimal value of the carriage return character */
    crlf[1] = 10; /* decimal value of the linefeed character */

    fileId = fopen("COM1", "r+"); /* open COM1 in read/write mode and return file id */

    sprintf(wrtBuf, "DM0%s", crlf); /* set instrument to numeric mode */
    fputs(wrtBuf, fileId); /* write data string to open file */
    for(cnt = 0; cnt < 10000; cnt++); /* delay to perform operations and send data */
    numberRd = rdData(rdBuf); /* read status */
    if(numberRd == 7) /* check to make sure that 7 status bytes were received */
        detStatus(rdBuf, numberRd, statusBytes); /* determine status */
    else /* incorrect number of bytes were received display error message to the standard output */
        printf("Display Numeric Mode: Expected 7 bytes, received %i bytes", numberRd);

    sprintf(wrtBuf, "M0%s", crlf); /* set instrument to xyY measurement mode */
    fputs(wrtBuf, fileId); /* write data string to open file */
    for(cnt = 0; cnt < 5000; cnt++); /* delay to perform operations and send data */
    numberRd = rdData(rdBuf); /* read status */
    if(numberRd == 7) /* check to make sure that 7 status bytes were received */
        detStatus(rdBuf, numberRd, statusBytes); /* determine status */
    else /* incorrect number of bytes were received display error message to the standard output */
        printf("xyY Measurement Mode: Expected 7 bytes, received %i bytes", numberRd);

    sprintf(wrtBuf, "R%s", crlf); /* create read string */
    fputs(wrtBuf, fileId); /* write data string to open file */
    numberRd = rdData(rdBuf); /* read data and status */
    if(numberRd >= 7) /* determine that at least 7 bytes were received */
    {
        detStatus(rdBuf, numberRd, statusBytes); /* determine status */
        if(numberRd == 49) /* if 49 bytes were received then a valid reading was received */
            sscanf(rdBuf, "%f%f%f%i%f", &data.x, &data.y, &data.Y, &data.T, &data.Delta_E); /* parse measured values */
    }
    else /* incorrect number of bytes were received display error message to the standard output */
        printf("Reading: Expected 49 bytes, received %i bytes", numberRd);
    fclose (fileId); /* close open file */
}
/* This function reads data from the COM port until carriage return / linefeed termination characters are detected. */
/* Once the termination characters are detected, the character array containing either the status or the valid data will */
/* be returned along with the number of bytes read. */

```

```

int rdData(char string[80])
{
    int    rdBuf;                                /* character read from com port */
    int    numberRd;                             /* total number of bytes read from com port */
    int    number;                               /* number of bytes read from com port */

    numberRd = 0;                               /* set total bytes read from COM port */
    number = 1;                                 /* set current bytes read from COM port */

    while(number > 0)                           /* read COM port until a crlf is encountered or 0 bytes are received*/
    {
        rdBuf = fgetc(fileId);                  /* read byte from open file */
        if(rdBuf ==crlf[1])                    /* determine if byte received was the linefeed character */
            if(string[numberRd - 1] == crlf[0]) /* determine if the previous byte was the carriage return character */
                number = 0;                    /* if carriage return and linefeed were receive exit loop */
        string[numberRd] = rdBuf;              /* put character read in character array */
        numberRd++;                            /* increment number of bytes read from com port */
    }
    return(numberRd);                           /* return the number of bytes read from com port */
}

/* This function will determine the instrument status */

void detStatus(char buf[80], int numberRd,int statusBytes[23])
{
    /* int statusBytes[23];    status byte response */
    /* [0] overall error      (0 no error / 1 error) */
    /* [1] out of calibration (0 in calibration / 1 out of calibration) */
    /* [2] invalid command   (0 valid / 1 invalid) */
    /* [3] backlight         (0 off / 1 on) */
    /* [4] overrange         (0 normal / 1 overrange) */
    /* [5] underrange        (0 normal / 1 underrange) */
    /* [6] power saver       (0 off / 1 on) */
    /* . */
    /* . */
    /* . */

    int  stat1Byte;
    int  stat2Byte;
    int  stat3Byte;
    int  stat4Byte;
    int  stat5Byte;

    stat1Byte = buf[numberRd - 7];              /* moving status byte from a char array to an integer. If the status byte */
    if(stat1Byte < 0)                          /* is > 128 then the result will be negative add a fixed value to make the */
        stat1Byte += 0x0100;                  /* status byte positive */

    if(stat1Byte & 0x80)                       /* check status byte 1 bit 8 to determine if an error occurred*/
        statusBytes[0] = 1;
    else
        statusBytes[0] = 0;
}

```

```
if(stat1Byte & 0x40)
    statusBytes[1] = 1;
else
    statusBytes[1] = 0;
    /* check status byte 1 bit 7 to determine if instrument is out of calibration*/

if(stat1Byte & 0x20)
    statusBytes[2] = 1;
else
    statusBytes[2] = 0;
    /* check status byte 1 bit 6 to determine if an invalid command was sent */

if(stat1Byte & 0x10)
    statusBytes[3] = 1;
else
    statusBytes[3] = 0;
    /* check status byte 1 bit 5 to determine if the backlight is on*/

if(stat1Byte & 0x08)
    statusBytes[4] = 1;
else
    statusBytes[4] = 0;
    /* check status byte 1 bit 4 to determine if an overrange condition occurred*/

if(stat1Byte & 0x04)
    statusBytes[5] = 1;
else
    statusBytes[5] = 0;
    /* check status byte 1 bit 3 to determine if an underrange condition occurred*/

if(stat1Byte & 0x02)
    statusBytes[6] = 1;
else
    statusBytes[6] = 0;
    /* check status byte 0 bit 2 to determine if the power saver feature is on */

.
.
.
    /* repeat the above for the remaining status bytes */
```

Status	00 11 00 40 11	b2 78 2a 40 46	52 33 31 c0 42
Error	No	Yes	No
Cal expired	No	No	Yes
Invalid command	No	Yes	No
Backlight	Off	On	On
Over-range	No	No	No
Under-range	No	No	No
Power saver	Off	On	On
Bar graph mode	RB/G	RG/B	GB/R
Reference option	Stored White Ref	Stored White Ref	Stored Measurement
Reference reading	1	9	3
Display mode	Numeric	Numeric	Numeric
Keypad lockout	Off	On	On
Chroma mode	xy	$\Delta u' \Delta v'$	XYZ
Luminance units	cd/m <sup>2</sup>	nt	f L
Display Disable	Off	Off	On
Hold	Off	On	On
Handheld not calibrated	No	No	No
Head not calibrated	No	No	No
Color Standard vacant	No	No	No
White ref vacant	No	No	No
Measurement vacant	No	No	No
Setup vacant	No	No	No
White reference	1	4	4
Color Standard	1	6	2

## Appendix C

### Product Specifications

**1. Color sensor configuration:**

- Four detectors matched to CIE 1931 Color Functions
- Acceptance angle of the Optical Detector Head (full angle): 9.0°
- Measurement Distance:

In contact for CRT displays, contact or non-contact for Flat Panel Displays or diffuse reflective panels. Maximum measurement distance will be limited by the spot size. See Section 12 for details.

**2. Capabilities of handheld unit:**

- Built-in display: 128x128 Liquid Crystal Graphics with backlight function
- Display modes (Numeric and CIE Plot):
 

CIE 1931 x, y, Y, CCT, ΔE
CIE 1931 Δx, Δy, Y, CCT, ΔE
CIE 1976 u', v', Y, CCT, ΔE
CIE 1976 Δu', Δv', Y, CCT, ΔE
- Display modes (Numeric only): CIE 1931 X, Y, Z, CCT
- Display modes (Analog Bar Graph): RGB color balance with regard to the reference
- Luminance units: cd/m<sup>2</sup>, fL, nit
- Display ranges:
 

Luminance:	0.10 - 10,000 cd/m <sup>2</sup> (for white light stimuli)
Chromaticity x, y (u', v'):	0.0048 - 0.8338 (0.0159 to 0.6233)
CCT:	2,500 - 50,000 K
Color Error (ΔE):	0.0 – 25.0
- Displayed precision :
 

Color (x, y, u', v')	4 Decimal places
Color XYZ	2 Decimal places
CCT	1 Kelvin
Luminance	0.01 ( 0.10 to 0.99 cd/m <sup>2</sup> )
	0.1 ( 1.0 to 99.9 cd/m <sup>2</sup> )
	1 ( 100 cd/m <sup>2</sup> and above )
RGB Bars	1%

**3. Accuracy (See conditions \*1 and \*2):**

- Chromaticity, (CIE 1931 x,y): ( ± )
 

at luminance levels, cd/m <sup>2</sup> ( 0.75 - 1.49 )	0.010
( 1.50 – 2.99 )	0.005
( 3.00 – 4.99 )	0.003
(5.0 and above	0.002

- Luminance:  
at luminance levels, cd/m<sup>2</sup> (1.0 and above) < 2% ±1 digit
- RGB Bars: < 1 %

**4. Repeatability (See condition \*3):**

- Chromaticity, (CIE 1931 x,y): (2σ)  
at luminance levels, cd/m<sup>2</sup> ( 0.75 - 0.99 ) 0.003  
( 1.00 – 2.99 ) 0.001  
( 3.0 and above ) 0.0005
- Luminance: (2σ)  
at luminance levels, cd/m<sup>2</sup> ( 1.00 and above ) < 1.0%
- RGB Bars (in Bar Graph Mode): < 1 %

**5. Inter-instrument agreement:**

For condition \*1, at luminance levels 3 – 350 cd/m<sup>2</sup>:

- Chromaticity, CIE 1931 Δx, Δy, maximum: ±0.002
- Luminance, difference (%): ±2.0

For condition \*4, for white:

- Chromaticity, CIE 1931 Δx, Δy, typical: ±0.0015
- Luminance, difference (%): ±1.5

**6. Polarization error/sensitivity (See condition \*5):** < 0.5%  
(% of CIE 1931 x, y and Luminance)

**7. Selectable range for internal data averaging:** 1 - 16 A/D readings per color calculation.

**8. Typical f1' (%) of Color Sensors** (more accurate color sensors can be installed upon request):

- X < 3.6 (combined accuracy of x1 and x2 detectors)
- Y < 2.0
- Z < 4.0

**9. Remote Interface:** RS-232 (fixed rate @ 9600 baud)

**10. Remote interface commands:**

All instrument features are accessible via Remote Interface (38 commands).

**11. Update rates (with internal averaging set to 1 A/D reading per color calculation):**

Display:	2 times /sec.
RS-232 (Display Enabled):	2 times /sec.
RS-232 (Display Disabled):	3 times /sec.

*(The instrument's response time will increase when the internal data averaging is increased).*

**12. Diameter of measurement area vs. measurement distance:**

Distance (in/mm):	In contact	3.0 / 76	6 / 152	12 / 305	24 / 610	36 / 914
Spot Diameter (in/mm):	1.6 / 40	2.0 / 52	2.5 / 64	3.5 / 88	5.3 / 136	7.2 / 184

(continued)

Distance (ft/m):	10 / 3.05	15 / 4.6	20 / 6.1	25 / 7.6	30 / 9.1	40 / 12.2
Spot Diameter (in/mm):	21 / 520	30 / 760	39 / 1000	49 / 1240	58 / 1480	77 / 1960

**13. Internal memory locations for storing data:**

Custom calibration matrixes (color and luminance):	5
Setups:	5
White references:	6 (pre-programmed with D65, 9300K, D50, D55, 3200K)
Color standards:	6 (pre-programmed with SMPTE-C, EBU, ITU REC.709, ADOBE RGB, DCI-P3)
Measurements:	9

**14. Standard calibrations:**

Colorimeter comes pre-programmed with calibration matrixes for CRT, FPD -CCFL, FPD-LED backlit displays. Custom calibrations can be performed upon request.

**15. Internal power source (DC):** Rechargeable NiCd battery pack

Recharge Time:	< 4 Hours
Battery Life (for new battery):	
Backlight Off:	~ 14 Hours
Backlight On:	~ 7 hours

**16. External power supply (AC input):**

Universal input Desktop Power Supply, TUV, CSA, UL Approved	
Input Power Rating:	100 – 240V, 50–60 Hz, 75 VA
Output Power Rating:	9V DC, 2.2A
Height:	36mm (1.4")
Width:	59mm (2.3")
Length:	112mm (4.4")
Weight (w/o AC Power Cord):	280g (0.62 lb)
Cable length (output):	1m (39")

*AC Power cord for a specific country or region can be requested at the time of order.*

**Optical detector head assembly:**

Diameter of rubber cup:	78mm (3.05")
Length:	218 mm (8.57")
Diameter of the Optical Head Tube:	63.5mm (2.50")
Thread size in the mounting plate:	1/4"-20 (for mounting on a tripod)
Weight:	680g (1.5 lb)
Cable Length (standard):	1.3m (5')
Cable Length (optional):	up to 3m ( or 12')

**17. Display (handheld) unit:**

Height:	130mm (5.10")
Width:	100mm (3.90")
Length:	280mm (11.0")
Weight:	750g (1.65 lb)

**18. Carrying case (empty):**

Height:	197mm (7.75")
Width:	508mm (20.0")
Length:	380mm (15.0")
Weight:	3.6kg (8.0 lb)

**19. Test conditions:**

- All tests were conducted in dark lab with controlled environment: (temperature:  $23\pm 2^{\circ}\text{C}$ , relative humidity:  $40\pm 10\%$ ).
- Measurements are referenced to a laboratory color standard (traceable to both NIST and PTB) and luminance standard (traceable to NIST).
- The optical head is in contact (for CRT display) or at 1" distance (for Flat Panel Displays).
- Typical luminance levels of standard displays on white @ 6500K:  
80 cd/m<sup>2</sup> for CRT, 200 cd/m<sup>2</sup> for FPD-CCFL, and 350 cd/m<sup>2</sup> for FPD-LED.
- The luminance adjustment range for illuminant A source ( CCT=2956K) is 0.2 to 2800 cd/m<sup>2</sup> .
- Warm-up time for SLS 9400: at least 30 min.
- Internal A/D averaging in SLS 9400 was set to 4 in all tests except where noted.
- Optical axis of the Detector Head is normal to the surface of the display in all tests.
- \*1 Measurements obtained over the color gamut of the standard displays.
- \*2 Measurements performed on illuminant A source.
- \*3 The chromaticity and luminance are measured on the standard FPD-LED on white (6500K) and illuminant A source (over the full range). A/D Averaging was set to 1 (no averaging) for the test.
- \*4 Measurements obtained on the standard displays at maximum luminance levels of white (@6500K).
- \*5 Measurements obtained on standard FPD-LED and FPD-CCFL displays at maximum levels of white (@ 6500K) and two rotational positions of the detector head:
  - 1) Vertical (default measurement position when mounted on a post or tripod) , and
  - 2) Horizontal (rotated 90<sup>0</sup> around optical axis).

\* Specifications are subject to change without notice.

## Appendix D

### Reference Information

#### Color Standards

Standard	CIE1931 Coordinate	Red	Green	Blue
DCI-P3 (SMPTE-231-2)	x	0.680	0.265	0.150
	y	0.320	0.690	0.060
ITU Rec.709	x	0.640	0.300	0.150
	y	0.330	0.600	0.060
Adobe RGB	x	0.640	0.210	0.150
	y	0.330	0.710	0.060
SMPTE-C	x	0.630	0.310	0.155
	y	0.340	0.595	0.070
EBU	x	0.640	0.290	0.150
	y	0.330	0.600	0.060

#### Standard Illuminants

Illuminant	Color Temperature, K	CIE1931 x	CIE1931 y
A	2856	0.4476	0.4074
3200K	3200	0.4230	0.3990
D50	5000	0.3457	0.3585
D55	5500	0.3324	0.3474
D65	6504	0.3127	0.3290
9300 K	9300	0.2848	0.2932

## **Appendix E**

### **Product Warranty**

# Product Warranty

## Warranty Provisions

UDT Instruments warrants the items delivered hereunder to be free from defects in material and workmanship, and to conform to current UDT Instruments specifications at the time of sale. Purchaser shall have a period of one year from date of acceptance of the items to return deficient items to UDT Instruments for correction. Material will be considered accepted 30 days after receipt by purchaser unless UDT Instruments is notified of acceptance earlier.

UDT Instruments agrees to repair or replace at the place of manufacture, without charge, all items returned, transportation prepaid, for inspection at the UDT Instruments factory within the warranty period, provided: (1) such inspection discloses to the satisfaction of UDT Instruments that the defects are as above specified; and, (2) the material has not been subjected to misuse, improper maintenance, negligence or accident, damaged by excessive radiation, voltage, current or otherwise damaged by misuse.

The item returned shall only be accepted when accompanied by a written statement setting forth the nature and suspected cause of the alleged deficiencies.

This warranty is expressly in lieu of all other warranties, express, implied or statutory, and all other obligations or liabilities on the part of UDT Instruments. In no event shall UDT Instruments be liable for claims, demands or damages of any nature, however denominated, except that UDT Instruments liability shall be to repair defective items at its factory or supply replacement parts in accordance with the terms of this warranty.

When equipment is shipped FOB UDT Instruments's factory, and when said equipment fails to perform according to specifications upon receipt, a claim should be made immediately against the shipping agency.

## Shipment and Payment

UDT Instruments payment terms are Net 30 days. Shipment will be FOB

8581 Aero Drive  
San Diego, CA 92123 USA  
TEL: 858 279-8034 FAX: 858 576-9286

## Warranty Return Procedure

**NOTE: If this device has warranty and calibration seals, all warranties and calibrations are void if these seals are broken.**

1. Please review terms of purchase and date of shipment to determine if product is warranted and whether or not it is within warranty period. Adjustment cannot be made for product out of warranty.
2. If product is subject to warranty, prior to return of product, telephone, write or FAX UDT Instruments at the above address.

Product malfunctions should be reported to the sales department at the earliest possible time, since there are many occasions when technical assistance may obviate the need for returning products or can prevent product damage. Upon verification that warranty service is required, the sales department will issue a Return Material Authorization Number (*RMA number*). The RMA number must appear on the outside of the shipping container for proper receipt.

3. It is necessary in all instances that the "Return Report" form be completed. Please photocopy and fill out the Return Report located in your manual.
4. Repack the product carefully in the same manner it was originally packaged, preferably using the original shipping carton and packaging material. Pack the completed Return Report with the product making sure that the RMA number is clearly visible on the outside of the container. Ship the product prepaid to UDT Instruments.
5. UDT Instruments will advise your company of its findings as to warranty consideration at the earliest possible time.

## **Appendix F**

### **Return Report**

# Return Report

Include a copy of this form when returning an instrument for service or repair.

RMA #: \_\_\_\_\_

Company Name: \_\_\_\_\_

Customer Name: \_\_\_\_\_

Address: \_\_\_\_\_

City: \_\_\_\_\_

Zip: \_\_\_\_\_

Country: \_\_\_\_\_

Phone: \_\_\_\_\_

Fax #: \_\_\_\_\_

**Instrument Information:**

Model #: \_\_\_\_\_

S/N: \_\_\_\_\_

**Problem Description:**

Describe the problem, include the instrument setup (Detailed information will help speed the repair process):

\_\_\_\_\_  
\_\_\_\_\_  
\_\_\_\_\_  
\_\_\_\_\_  
\_\_\_\_\_  
\_\_\_\_\_  
\_\_\_\_\_

How many hours did the instrument operate before the problem was noticed?

\_\_\_\_\_  
\_\_\_\_\_  
\_\_\_\_\_  
\_\_\_\_\_

Other comments:

\_\_\_\_\_  
\_\_\_\_\_  
\_\_\_\_\_  
\_\_\_\_\_



